

Tenth Year of Service

RADIO ENGINEERING

Vol. X OCTOBER, 1930 No. 10

IN THIS ISSUE

■■■■■■■■

ELECTRON TUBE RELAYS

(Page Twenty-Three)

By H. B. Stevens

PRACTICAL LABORATORY OSCILLATORS

(Page Twenty-Eight)

By A. Binneweg, Jr.

SPEAKING ABOUT THAT 1930-31 PRODUCTION

(Page Thirty-One)

By Austin C. Lescarboura

A NEW POWER DETECTOR SYSTEM

(Page Thirty-Three)

By Dr. Paul G. Weiller

MIXING CIRCUITS AND TRANSFORMERS

(Page Thirty-Five)

By E. W. D'Arcy

RADIO PRODUCTION SPEEDED UP AND MADE EFFICIENT

(Page Forty-One)

By H. G. Cisin

*Sold only by subscription
\$2.00 per year*



The Journal of the Radio Industry

CENCO-HYPERVAC PUMP



More than four times as fast as any other pump for automatic exhaust machines to work below a micron—but only 17x13x12 inches overall, weighing only 83 lbs., and requiring but 1/3 h.p. for drive. Inspection requirement for vacuum, 0.05 micron.

Instant Recovery that Stops Shrinkage

Broken tubes lose their menace when automatic exhaust machines operate from Cenco-Hypervac pumps. By a dimensional capacity greater than 200 litres per minute, by a new low order of vacuum in the 0.05 microns region . . . and by automatic pre-rectification of all oil reaching the rotary finishing state—the Cenco-Hypervac pump delivers the most critical need of automatic exhaust, instant recovery.

Follow the steep curve of Cenco-Hypervac exhaust . . . almost vertical along the pressure axis far into the tenths micron region. There is a new picture of high speed pumping. Notice how an extra volume of 22 litres is brought to half a micron in less than three minutes. Imagine this exhaust rate acting against normal tube and line volumes where the time axis takes seconds as major units—that is a graphic view of instant recovery, of an ample margin of safety to cover breakage, when machines are Cenco-Hypervac equipped.

70 tenths of a micron in Seconds

Exhaust curves with the Cenco-Hypervac have almost vertical slopes to half a micron. This curve is for a volume of 22 litres. With smaller volumes, displacing the curve left, time is measured in seconds.

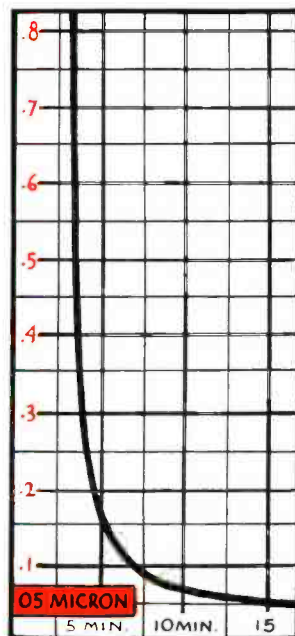

460 East Ohio Street
Chicago, Illinois

CENTRAL SCIENTIFIC COMPANY
CENCO HIGH VACUUM PUMPS
 Hyvac Megavac Super TRADE MARK CENCO REGISTERED vac Rotovac Hypervac
 NEW YORK - BOSTON - CHICAGO - TORONTO - LOS ANGELES

Prompt Service On High Quality Material

WITH the largest producing unit in the industry concentrated on just one product, Formica is always ready to give the radio industry prompt service on material of high quality and uniformity.

Tubing, punch parts, sheets, rods can be shipped very promptly. You will find the fabricated parts are accurately handled. And if you do the fabricating yourself, material suitable for any requirement is available.

THE FORMICA INSULATION CO.

4646 Spring Grove Avenue
Cincinnati, Ohio



RADIO ENGINEERING

Reg. U. S. Patent Office

Member, Audit Bureau of Circulations

Western Editor
ULMER G. TURNER

Editor
DONALD McNICOL

Associate Editor
AUSTIN C. LESCARBOURA

Vol. X

October, 1930

Number 10

Contents

	PAGE
Editorial	4
Impressions and Expressions <i>By Austin C. Lescarbourea, Associate Editor</i>	16
Electron Tube Relays..... <i>By H. B. Stevens</i>	23
A-C. Voltage Found to Vary Greatly in Different Localities..... <i>By H. G. Cisin</i>	26
Practical Laboratory Oscillators..... <i>By A. Binneweg, Jr.</i>	28
Speaking About That 1930-31 Production <i>By Austin C. Lescarbourea</i>	31
A New Power Detector System.... <i>By Dr. Paul G. Weidler</i>	33
Mixing Circuits and Transformers..... <i>By E. W. D'Arcy</i>	35
Engineering the Battery Radio Set <i>By W. H. Hoffman and Don R. Mix</i>	38
Radio Production Speeded Up and Made Efficient <i>By H. G. Cisin</i>	41

Departments

News of the Industry.....	46
New Developments of the Month.....	48
Buyers' Directory.....	56
Index of Advertisers.....	64

The Radio Show in New York

THE Radio Show held in Madison Square Garden, New York, throughout the week of September 22, was largely attended by the public willing to pay one dollar per head admission.

Without comparing this year's crowd with the numbers of persons who attended the Garden Shows of a few years ago, it should be agreed that the attendance was satisfactory. There are very few industries which, in September, 1930, could have attracted half the number of visitors that attended the Radio Trade Show.

It is true that the manufacturers, engineers and radio dealers who attended, saw greater evidence of improvement in receivers than it was possible for the public to observe. The receivers of practically every exhibitor included refinements over the offerings of previous years. Anyone who cares to gauge the measure of improvement has but to compare the 1930 receivers with the products of 1925, but five years ago. In design, appearance and performance the radio set of 1930 is an instrument that will sell easily wherever there is demand and wherever the purchase can be financed.

As an indication of what may be expected during the coming Fall and Winter in the way of radio sales, the show may be said to have been very favorable. Thousands attended the show in order to decide what sort of receiver to buy and there is no doubt that, as a result, in the coming weeks retail sales will show a marked increase.

Published Monthly by

Bryan Davis Publishing Co., Inc.

52 Vanderbilt Ave.

New York City

Publishing
AVIATION ENGINEERING
RADIO ENGINEERING
PROTECTION ENGINEERING

Entered as second class matter at the post office at Albany, N. Y., January 9, 1925, under the act of March 3, 1879.

Publication Office—North Broadway—Albany, New York
Chicago Office—333 N. Michigan Ave.—Charles H. Farrell, Mgr.
Cleveland Office—10515 Wilbur Avenue—James C. Munn, Mgr.
St. Louis Office—505 Star Building—F. J. Wright
Kansas City Office—306 Coca Cola Building—R. W. Mitchell
San Francisco Office—318 Kohl Bldg.—R. J. Birch
Los Angeles Office—846 S. Broadway—R. J. Birch

Bryan S. Davis,
President

James A. Walker,
Secretary

E. M. Bacon,
Advertising Manager

Yearly subscription rate \$2.00 in U. S. and Canada; \$3.00 in foreign countries.

fastenings
 How they are
 made by leaders in
 the metal working
 industries . . .

Free!
to plant executives

This book was prepared for you with the cooperation of fourteen of the most prominent manufacturers in their respective fields, who permitted a nationally known firm of engineers to enter their plants and make studies of fastening methods which have proved particularly advantageous.

Every plant executive who is interested in the production of a product made wholly or partly of metal will find "Fastenings" interesting and helpful. Distribution of the book must be limited to those concerned with production, who may obtain it free.

CLIP COUPON TO YOUR LETTERHEAD

PARKER-KALON CORPORATION
 Dept. L, 190-198 Varick Street, New York, N. Y.

Send a free copy of "Fastenings" marked for the personal attention of:

Name and Title.....

Company.....

Street and City.....

E d i t o r i a l

October, 1930

JOHN J. CARTY RETIRES

A NEWS item of interest to all men engaged in electric communication, of whatever form, is that John J. Carty has retired from active service.

There are but few men who have been associated with General Carty over the entire term of his occupation with telegraphy, telephony and radio. These few will wonder what he will find at hand to engross his attention from now on.

General Carty entered telephone service in 1879, when telephony was little more than a scientific curiosity. He was then eighteen years of age. The engineering ability he acquired was woven from the rugged threads of experience. His great success as an engineer and as an executive is an example of what natural talent and zeal coupled with plain sanity may accomplish in the cause of science and of industry without the impulse of patronage or the prestige of early academic honors.

From the advent of the telephone in 1876, telephony in its plant engineering followed closely the engineering of telegraphy, which had its start thirty years earlier. An event which marked the departure of telephone from telegraph engineering was the presentation by J. J. Carty of a paper before the A.I.E.E., in 1891, entitled "Inductive Disturbances in Telephone Circuits." It is likely that no other technical paper on communication ever had so wide a reading and study as had this one. From that time forward telephone engineering became an art apart and in advance of telegraph engineering and so continued until quite recent times.

General Carty may well rest from his labors, and all men in communication will wish him peace and contentment.

The news of his retirement is like a breath from other days. One may visualize Franklin retiring from public life and electrical experiments, after which he enjoyed a few years of peaceful contemplation of the achievements of a busy life; Maxwell displaying to kindly visitors the bagpipes which at the Hoogly saved the life of a soldier forebear and writing letters about everything and everybody but himself; Faraday, in the late years, in the evening sitting long at the western window watching the glories of the sunset, and Morse retiring to Poughkeepsie where the peace of family routine was disturbed only occasionally by excursions here and there where further honors awaited him.

Otium cum dignitate! To some are given a philosophy for use in later life. Our hope is that General Carty is one of these blessed few.

THE MARKET FOR TUBES

THE benefits of research on the part of a host of physicists working on vacuum tube development are spreading over various non-radio industries. Radio engineers, familiar with the tube art, are, in growing numbers, finding opportunity for the application of the tube to a host of new uses.

It is gratifying that those engineers who have specialized in tube work and who are alive to the tube's seemingly unending uses look to RADIO ENGINEERING for dependable month-to-month information about advances in this art. The technical articles this journal publishes on the technique of tube design and manufacture are instructive and educational, as is attested by a large increase in correspondence on this subject.

In the main wherever new uses are discovered for tubes the applications will for many years be made by radio engineers.

SERVICING

SEVERAL radio manufacturers have worked out, with some degree of success, sold receiver servicing which is independent of or supplementary to servicing done by dealers. A canvass carried out by RADIO ENGINEERING brings to the surface the viewpoint of dealers that there is more that can be done by manufacturers in this respect.

Dealer economics demands that the dealer and whatever he employs in the way of staff should, in the main, concentrate on sales and showroom service. In the smaller localities it appears that dealers are not averse to servicing sold sets, this so that servicing may be prompt. Obviously, where a given manufacturer's sets are not placed in sufficient density, servicing by the manufacturer would not be an economical undertaking.

In the larger towns and in cities many dealers feel that they should be relieved of the task of keeping radio receivers sold, except for emergency service when the manufacturer's representative is not reasonably available.

The problem is one well worth consideration by the RMA and the NFRA.

Donald Mc Nicol
Editor.

ANACONDA
 from mine to consumer



REG. U.S. PAT. OFF.



Textile winding in Anaconda Magnet Wire Mill.



Anaconda safeguards quality from mine to consumer—provides a nation-wide service, prompt, dependable, complete.

ANACONDA MAGNET WIRE . . .

*In all sizes and
 insulations . . .*

Anaconda Magnet Wire is available in all standard sizes and insulations . . . May we discuss your requirements with you?

ANACONDA WIRE AND CABLE COMPANY

General Offices: 25 Broadway, New York City
 Chicago Office: 20 North Wacker Drive Bldg.

Magnet Wire Mills at
 Muskegon, Mich.; Anderson, Ind.; Sycamore, Ill.
Sales Offices in Principal Cities

CRC SOCKETS



Engineering logic dictates the following requirements in tube sockets—low capacity between contacts—large size solder terminals—tempered steel reinforcing springs to insure **PERMANENT** contact. All of these features, and many more, are incorporated in C R C Sockets. Write for samples.

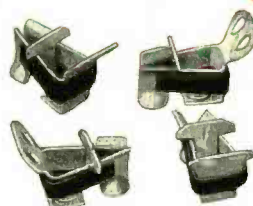

To manufacturers who have assembling facilities, C R C CLIPS are now available—either stock models or to your own specifications. Samples upon request.

SOCKETS

CENTRAL RADIO CORPORATION

156 ROOSEVELT AVENUE

Frank A. Emmet Sales Co.
Los Angeles, California

West Coast Representatives

BELOIT, WISCONSIN.

R. C. James & Co.
Seattle, Washington.

ARE BUILT TO STAND the **G A F F**

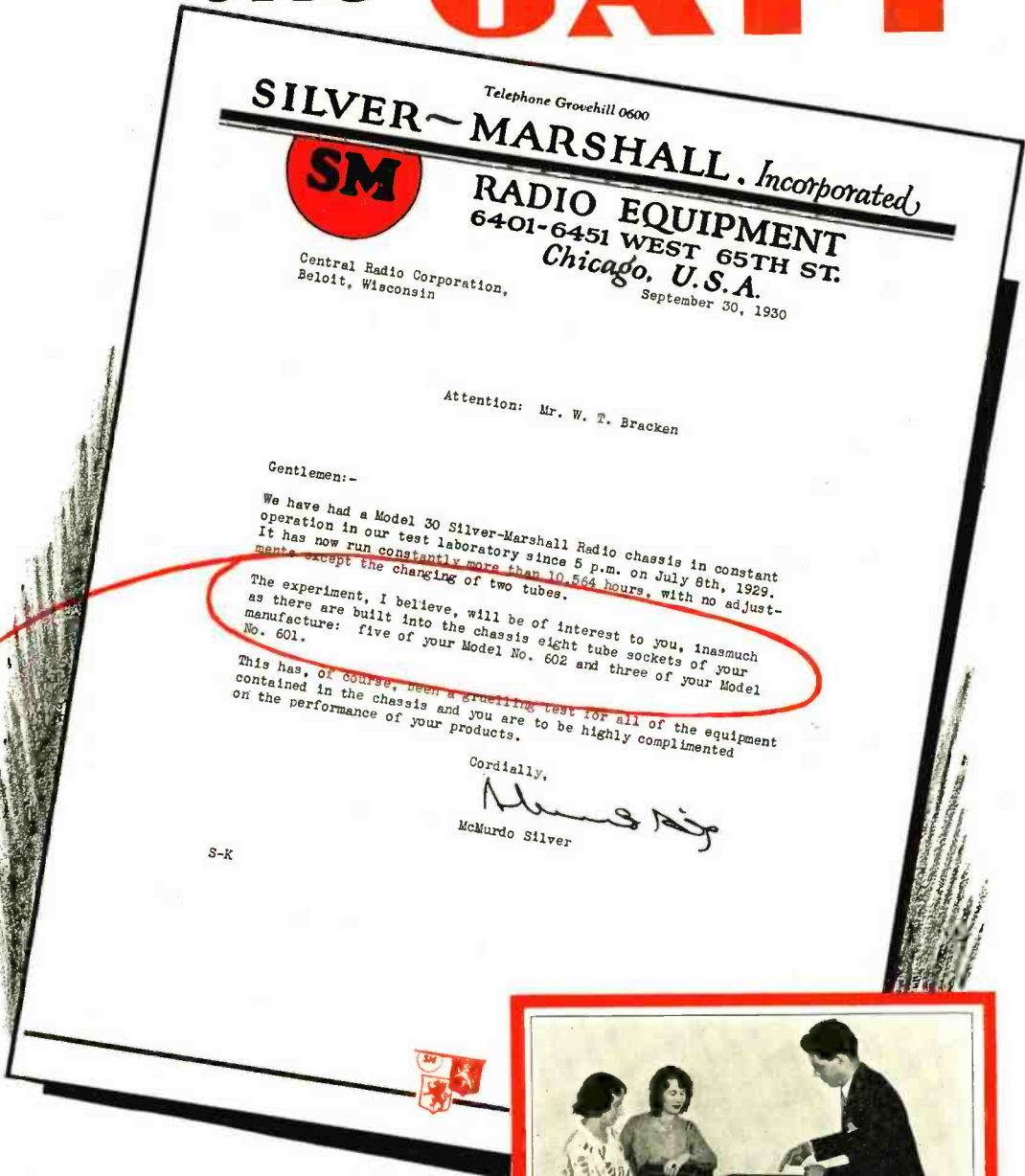

Telephone Grovehill 0600
SILVER-MARSHALL, Incorporated



RADIO EQUIPMENT
6401-6451 WEST 65TH ST.
Chicago, U.S.A.
September 30, 1930

Central Radio Corporation,
Beloit, Wisconsin

Attention: Mr. W. T. Bracken

Gentlemen:-

We have had a Model 30 Silver-Marshall Radio chassis in constant operation in our test laboratory since 5 p.m. on July 8th, 1929. It has now run constantly more than 10,564 hours, with no adjustments except the changing of two tubes.

The experiment, I believe, will be of interest to you, inasmuch as there are built into the chassis eight tube sockets of your manufacture: five of your Model No. 602 and three of your Model No. 601.

This has, of course, been a grueling test for all of the equipment contained in the chassis and you are to be highly complimented on the performance of your products.

Cordially,

McMurdo Silver
McMurdo Silver

S-K



McMurdo Silver, president of Silver-Marshall, is shown in the accompanying photograph explaining the working parts of the amazing Life Test Set.



2 more great Manufacturers endorse National Union Tubes

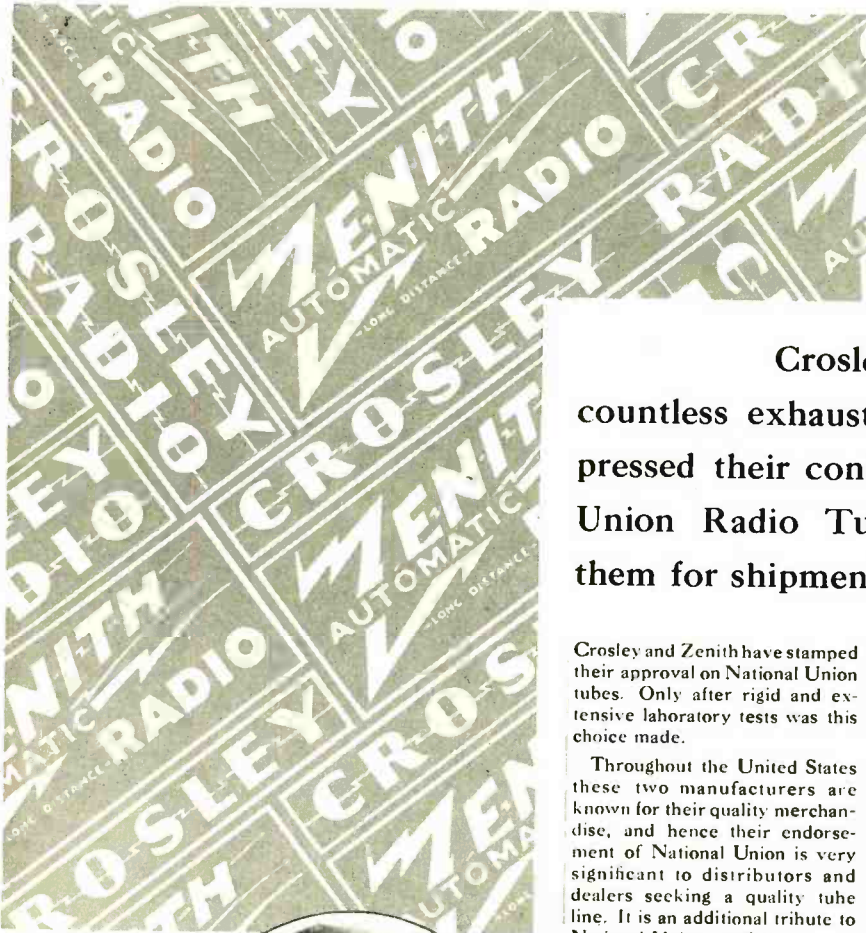

Crosley and Zenith, after countless exhaustive tests, have expressed their confidence in National Union Radio Tubes by approving them for shipment in their latest sets.

Crosley and Zenith have stamped their approval on National Union tubes. Only after rigid and extensive laboratory tests was this choice made.

Throughout the United States these two manufacturers are known for their quality merchandise, and hence their endorsement of National Union is very significant to distributors and dealers seeking a quality tube line. It is an additional tribute to National Union quality.

In the last seven months National Union has jumped to an enviable position in the radio industry. No other independent tube today is offered as standard equipment by as many manufacturers as National Union.

This phenomenal advancement can be attributed primarily to the work of Dr. Ralph E. Myers, Vice President in charge of En-

gineering and Production, who came to National Union with fifteen of his staff early this spring from Westinghouse Lamp Company. To these Radio Engineers go the credit. They are the men who perfected the quality tubes that have won the approval of Crosley and Zenith and other famous manufacturers.

TEST THESE TUBES YOURSELF. If you have never given National Union tubes a trial in your own sets do so at once. You will be amazed and delighted at the new clarity of tone. Then realize the sales opportunities these quality tubes will give you.

National Union jobbers will gladly explain our 6-fact profit plan and our theatre-lobby store display plan. If you do not anticipate a call from your jobber in the next day or two, write or wire direct to main office in New York.



DR. RALPH E. MYERS

World famous scientist, physicist, college professor, maker of a billion radio tubes—designer of the new National Union radio tubes. When he joined National Union in March, 1930, he brought with him 15 of his ablest engineers.

**NATIONAL UNION RADIO CORPORATION
400 MADISON AVENUE • NEW YORK CITY**

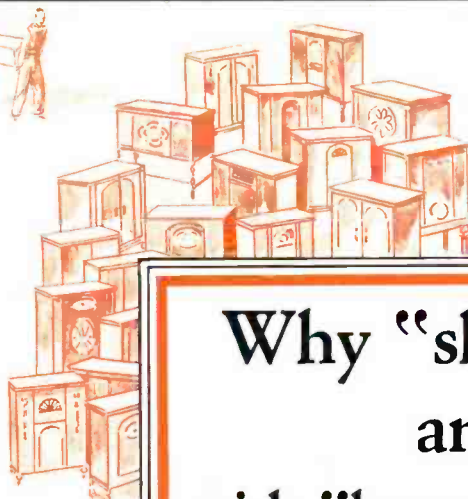

Why "short" your sales and profits with "long chance" condensers

THE period in the life of any receiver, of greatest importance to its manufacturer, is *after it is sold!* The manufacturer is not merely selling an item of merchandise—he is really selling a *service*. If that service is imperfect—subject to interruptions—it is a direct reflection on the integrity or ability of the individual or firm who built the set. As such it cannot help but injure their business and standing in the trade.

Set builders and manufacturers who expect to profit from the sale of products turned out on a *price* basis, alone, are not only laying up future trouble for themselves—but for their distributors—and for their dealers as well. Short cuts to quality are too apt to develop into short circuits! Every musical note, every

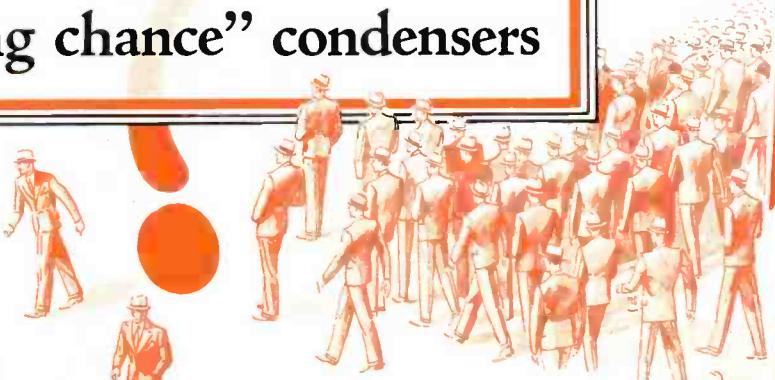

syllable of speech that a set reproduces is affected by the quality of the fixed condensers. They must store, transfer, or stock electrical energy with unflinching accuracy and minimum loss. Why risk reassembly and service losses by using "long chance" condensers with uncertain dependability? Sangamo Fixed Condensers are accurate—and *stay* accurate! Sangamo standards of precision have made it possible for manufacturers and custom set builders to eliminate condenser troubles. The standard line of Sangamo Fixed Condensers leaves the factory tested to maximum variation of 10%. The reliability of these ratings is attested to by a number of nationally known radio manufacturers. Sangamo is equally reliable as a source of supply.



SANGAMO ELECTRIC CO.

SPRINGFIELD, ILLINOIS, U. S. A.

Manufacturers of Precision Electrical Apparatus for 30 years



(see reverse side)

Nothing takes the place of TONE QUALITY in a radio receiving set

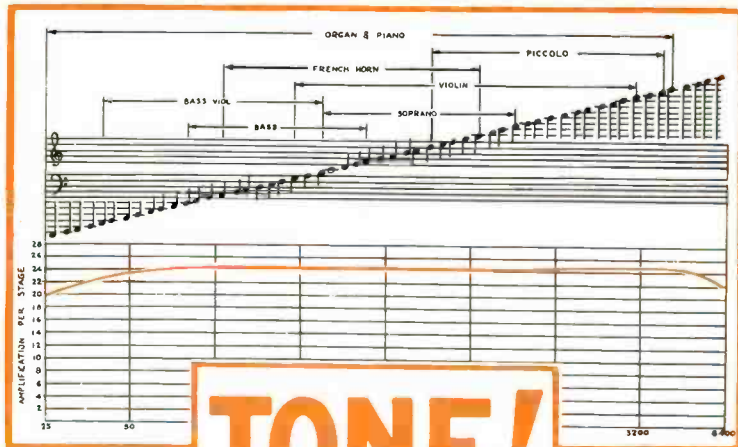

TONE!

Curve of Type "A" or Sangamo Straight Audio Transformer showing uniformity of amplification at all audible frequencies.

Sangamo Transformers in the "audio end" insure true tone!

"X" Line Transformers

Type AX straight audio amplification. List price.....\$6.00

Type BX Push-pull Input unit. List price.....\$6.50

Type CX-171 Push-pull Output Transformer, for 171 or 250 power output tubes for cone speaker. List price.....\$6.50

Type DX, same as CX except for 210 and 112 power tubes. List price.....\$6.50

Type HX Push-pull Output for 171 or 250 Power Output tubes to match the impedance of moving coil of Dynamic loud speakers. List price.....\$6.50

Type GX, same as HX except for 210 and 112 power tubes. List price.....\$6.50

Type E Output Choke to match impedance of the various type power tubes. List price.....\$5.00

"A" Line Transformers

Similar to X Line but with special core metal to give greater amplification at low frequencies

Type A straight audio amplification. List price.....\$10.00

Type B Push-pull Input Transformer for all tubes. List price.....\$12.00

Type C-171 Push-pull Output, for 171 or 250 type power tubes with cone speaker.....\$12.00

Type D-210, same as C except for 210 and 112 power tubes.....\$12.00

Type H-171, Push-pull Output for 171 or 250 power tubes for Dynamic Speaker. List price.....\$12.00

Type G-210, same as type H except for 210 and 112 tubes.....\$12.00

Type F Plate Impedance for use as a choke to prevent oscillation and for impedance coupled amplifiers. List price.....\$5.00

The Sangamo Type "A" Condenser



Every sound characteristic is affected by the quality of the fixed condensers in a set. Sangamo builds accurate mica condensers, molded within an overall enclosure of genuine bakelite with only the terminals brought outside. Moisture, heat, shocks or jars will not alter their characteristics nor affect operation after the set leaves the factory.

Sangamo "Illini" Condensers



"Illini" Condensers are standard with those manufacturers who insist on ratings being actually what the specifications call for. Manufactured by exclusively designed equipment, held to the tolerances your engineering department demands, Sangamo Condensers will reduce to a negligible quantity inspection department rejects and "reassembly" losses in profit.

Sangamo High Voltage Condensers

Tested at 5000 volts D. C. and 3500 A. C. and built to Sangamo standards, known throughout the radio world, amateurs, commercial men and manufacturers have learned to depend on Sangamo High Voltage Condensers. Accurately rated and adequately tested—these condensers offer the maximum protection in high voltage, high frequency circuits.

Prices on request

PIN THIS TO YOUR LETTERHEAD AND MAIL

SANGAMO ELECTRIC CO.
Springfield, Illinois, U. S. A., Dept. V-942

(For manufacturers) I am interested in engineering data regarding your transformers and condensers.

(For set builders) Please send circulars describing your apparatus and latest audio hook-ups. I enclose 10c to cover cost of mailing.

Name.....

Address.....

Unusual facilities for furnishing transformers with or without cases ready for mounting and quick assembly with the receiver. Prices on application.

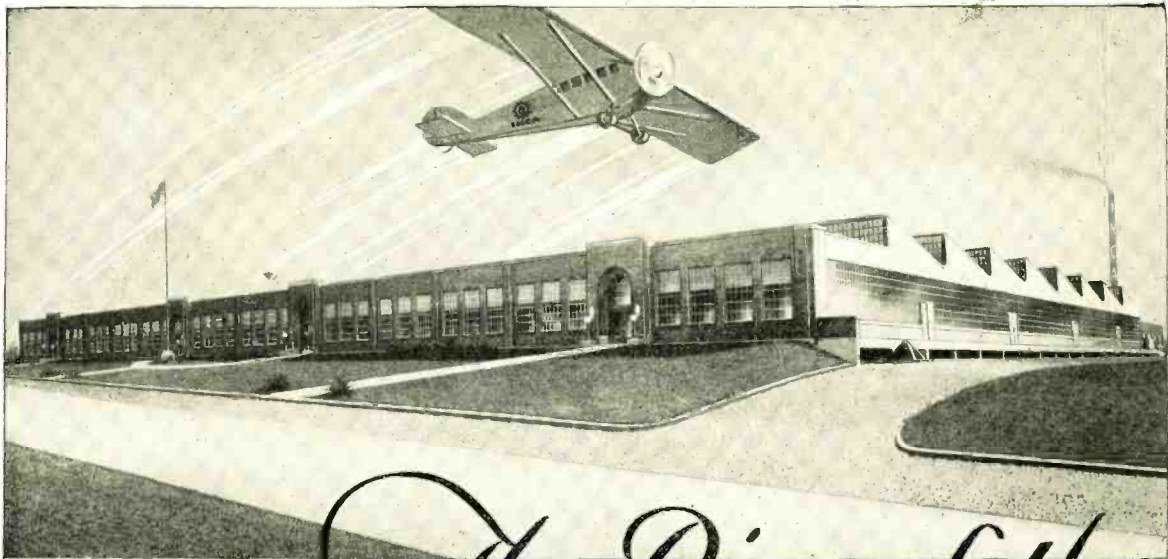

The Rise of the **INCA INDUSTRY**

ONE year ago the name Inca was presented to the trade for the first time, offering a new and dependable source of magnet wire and coils. The first unit of a great plant had just been completed and modernly equipped. There followed shortly a second unit, trebling the factory's capacity of output. Last April affiliation as a division of National Electric Products Corporation, providing a direct source of copper was announced. The establishment of a plant at Los Angeles, California, providing manufacturing, distribution and service facilities on the West Coast, constitutes another forward step in the progress of Inca.

In actual usage it was soon found that Inca products measured up to the promises made for them. Sound, steady growth followed, with a rising preference for the Inca trade-mark. Today Inca is widely recognized as America's great source of magnet wire and coils.

Inca's success has been built upon a solid foundation for permanent growth. Plant, machinery, engineering are all based upon a knowledge of magnet wire and coils accumulated from the pioneer days of the radio and electrical industries.

While Inca is proud of its first year's achievements, it is more concerned with opportunities for future service.

*Magnet Wire
Coils*



*Symbolic of the best
in the copper wire
industry*

*Let Inca engineers help you with the satisfactory
solution of your magnet wire and coil problems.*

**NATIONAL ELECTRIC PRODUCTS CORPORATION
INCA MANUFACTURING DIVISION**

Copper Wire Products—Fort Wayne, Indiana

EASTERN OFFICE: Newark, New Jersey

Industrial Office Building

WESTERN PLANT AND OFFICE: 1547 Venice Blvd., Los Angeles, California

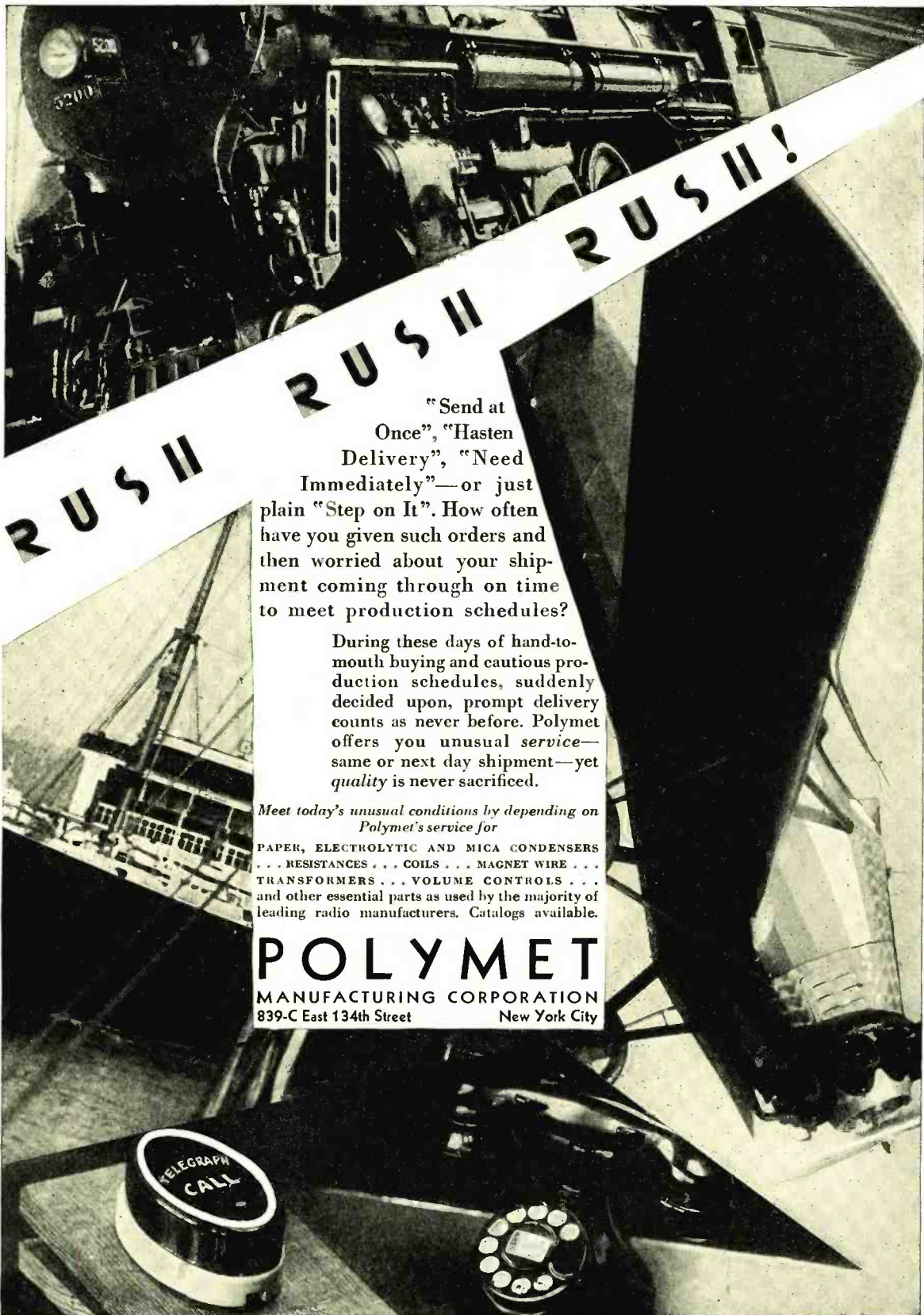

RUSH RUSH RUSH!

"Send at Once", "Hasten Delivery", "Need Immediately"—or just plain "Step on It". How often have you given such orders and then worried about your shipment coming through on time to meet production schedules?

During these days of hand-to-mouth buying and cautious production schedules, suddenly decided upon, prompt delivery counts as never before. Polymet offers you unusual service—same or next day shipment—yet quality is never sacrificed.

Meet today's unusual conditions by depending on Polymet's service for

PAPER, ELECTROLYTIC AND MICA CONDENSERS
 . . . RESISTANCES . . . COILS . . . MAGNET WIRE . . .
 TRANSFORMERS . . . VOLUME CONTROLS . . .
 and other essential parts as used by the majority of
 leading radio manufacturers. Catalogs available.

POLYMET
 MANUFACTURING CORPORATION
 839-C East 134th Street New York City

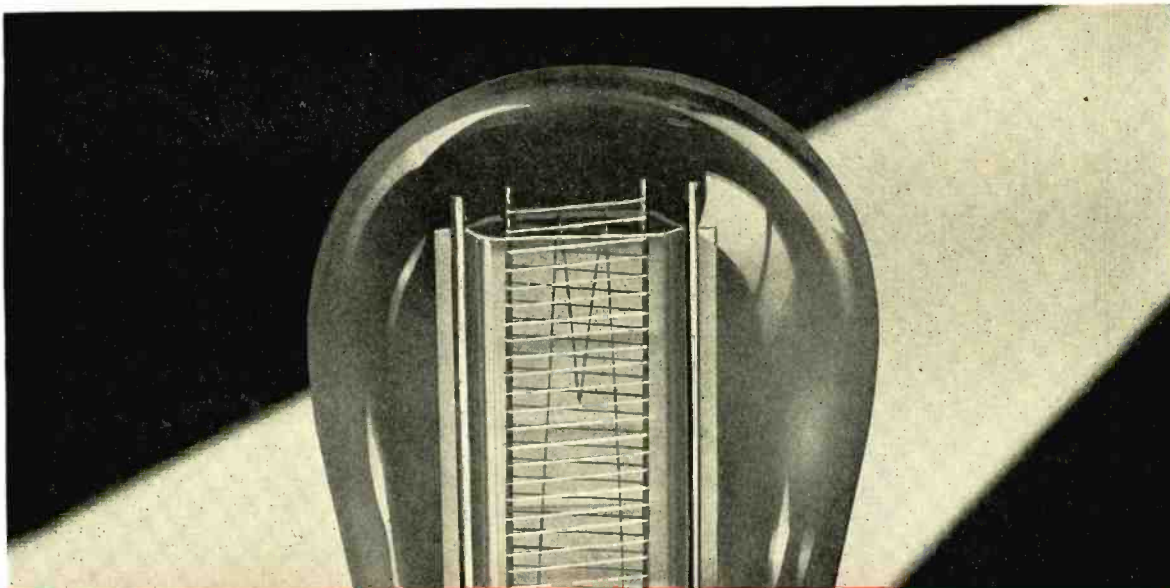

For Grids - - A New High Quality MOLYBDENUM WIRE by FANSTEEL

NEVER before has Molybdenum been produced commercially so pure, so uniform, so easy to fabricate as this new Fansteel Molybdenum. It is easily de-gassed, easily shaped, easily fastened to support rods without embrittlement—and grids can be depended upon to hold their shape at high temperatures without distortion.

Fansteel Molybdenum Wire is made in Fansteel's own plant on a quantity-production basis under strict laboratory control—*it's uniform*. Give this new grid wire a good fair trial—watch your quality go up and your rejections and costs come down.

Standard diameters are stocked for immediate delivery—special sizes quickly drawn to order. Fansteel is your best source of supply for vacuum tube metals in wire, sheets, bars, rods, and finished shapes, Fansteel refines direct from basic materials.

Tube manufacturers are invited to wire or write for samples and prices.

FANSTEEL
PRODUCTS COMPANY, Inc.
NORTH CHICAGO, ILLINOIS

TANTALUM • TUNGSTEN • MOLYBDENUM • CAESIUM • RUBIDIUM • ALLOYS

VOLUME CONTROLS *by* CLAROSTAT

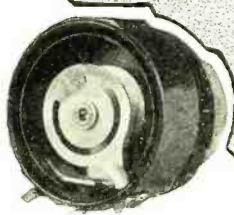

Open Type
($\frac{3}{8}$ " Deep)



Duo Type



Constant
Impedance
Control

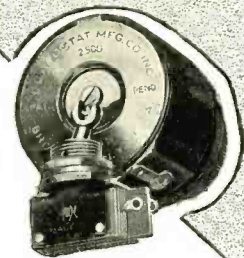

Switch Type

THE Open Type Clarostat Volume Control — the reliable Clarostat design, construction and reliability in compact form. Case measures only $\frac{5}{8}$ inch deep.

SPECIFY CLAROSTAT! That's all. For that name stands for the most advanced design and refined construction in control devices. It stands for the products of an organization long experienced in supplying the most rigid demands of the radio industry. And it stands for controls of any resistance range, regulation curve, combination and switching arrangement to meet your exact requirements. Specify CLAROSTAT—and you solve your control problems!

BULLETINS :

On Volume Controls, Constant Impedance devices and other Clarostat Resistors will gladly be sent upon request.

CLAROSTAT MFG. CO. 285-287 N. 6TH ST. BKLYN. N.Y.

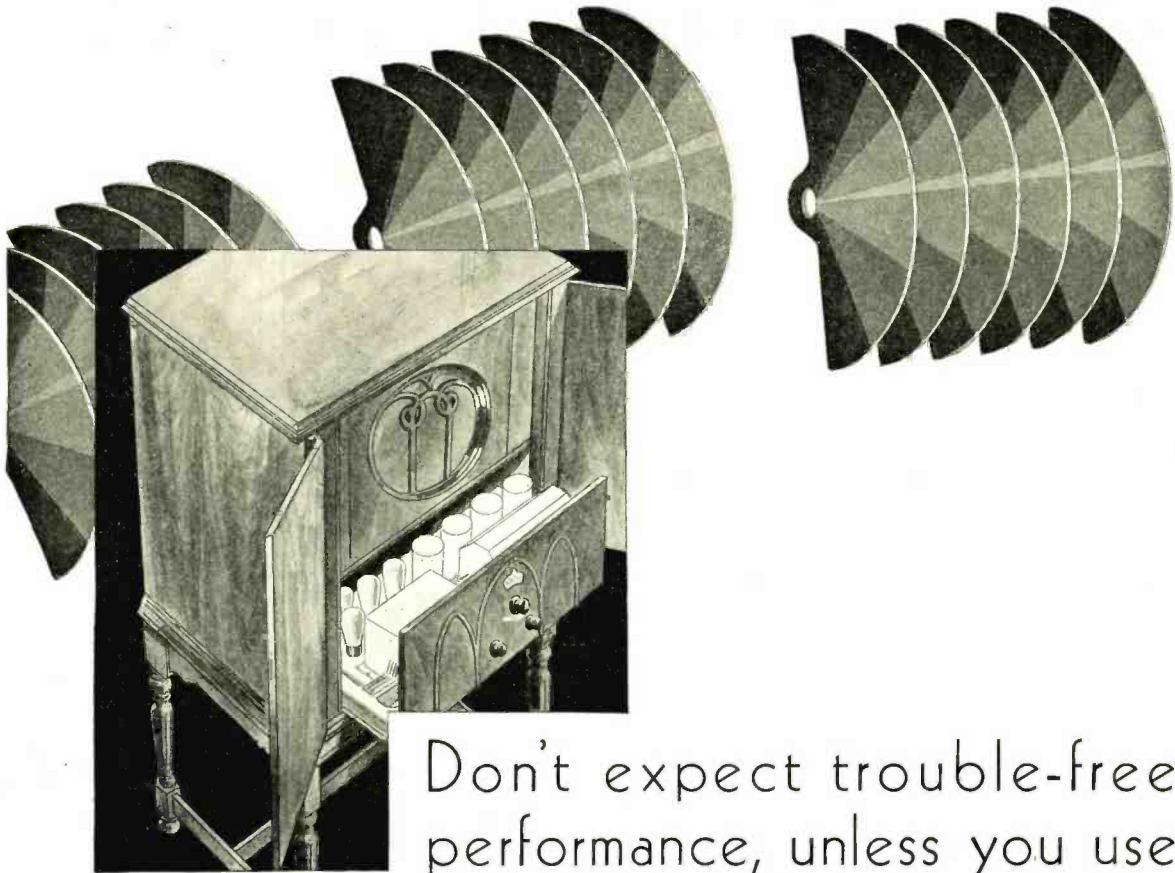

Don't expect trouble-free performance, unless you use All-Aluminum Condenser Blades

The quality of materials in the sets that bear your firm name has much to do with your reputation.

The leading radio companies standardize on blades for variable condensers made of solid Alcoa Aluminum Sheet. These firms know that blades turned out "at a price" prove costly in the long run. Efficiency of the sets may be impaired—sales lost.

The special Alcoa Aluminum Sheet developed for these blades is non-microphonic. It has a tolerance limited to .001 inch. Within a sheet, variation never exceeds .0005 inch.

Alcoa Aluminum has the highest efficiency, weight for weight, of any metal used in set building. It is the

ideal metal for many uses. Weighing only $\frac{1}{3}$ as much as old-fashioned metals, it produces light weight parts. Supports can be made lighter. There is less danger of misalignment in transit. And Alcoa Aluminum stays bright—will not rust—is non-microphonic.

Alcoa Aluminum is the only metal you can use for the electrodes of electrolytic condensers. Used for foil condensers, variable condenser blades, shielding, wire and cast parts, it makes a good radio better. Our nearest office will gladly supply you with full information on the use and fabrication of Alcoa Aluminum for any purpose you may have in mind. ALUMINUM COMPANY of AMERICA; 2468 Oliver Building, PITTSBURGH, PENNSYLVANIA.



THE METAL THAT IS TUNED TO RADIO

Impressions and Expressions

By AUSTIN C. LESCARBOURA

Turning Wheels

ONE radio plant after another is starting up again on actual, serious, and we hope profitable production. Wheels are turning once more. Contrary to the fear so often expressed in the recent past with regard to the welfare of the radio industry, the spirits of most of us are slowly but surely rising to new heights of optimism. Those organizations which made use of the lull for the purpose of perfecting their personnel, their equipment, their products and their merchandising plans, are now coming into their own. They did not waste their spare time. As in war, so in industry, a breathing spell, an armistice, or a truce, may be a good thing. It enables one to attend to many details which have gone along unnoticed or at least not attended to during the pressure of the things of the moment. The radio industry has had ample opportunity to bury its dead ones—poor personnel, poor ideas, poor engineering, poor production, and poor merchandising. The battle is on again. May the best man win.

Discount Riots

SOME tube manufactures, we learn with surprise, are giving the dealers 40, 20, 10 and 2 per cent discounts, or something of that order. We don't know what they grant jobbers, or again their local representatives. But at any rate, we have here what appear to be discounts run riot.

Bad, bad business. If a product cannot stand on its own feet and command a fair price from jobber and dealer and public, then it is time to redesign that product and make it so it can battle for a place on the market, at a profit. Our experience with jobbers and dealers in the past has been that they squander their discounts just as rapidly as we pass them on to the trade. Give a dealer 50 off, and he'll get rid of the extra ten. Give him another 10, and he'll get rid of that, too. What is necessary right now is to apply the brakes on easy discounts. If a salesman cannot sell your products at a reasonable discount and with profit to all concerned, it is time to find another sales manager or salesman. Anybody can sell at a loss.

Television Crawls Ahead

REMARKABLE activity in television of late. Despite the sad pronouncements of some leaders of our industry, there are workers going ahead with the development work. That old saying about "The poor fool did not know it couldn't be done, and so he went ahead and did it," may well apply to television. The big shots may be caught napping, after all.

It seems that most of the work continues in the 48-line field. However, startling pictures are being obtained. Recently we witnessed playettes in silhouette form, furnishing good entertainment. We also studied some good half-tones. If only those television fellows would get out of the haywire stage and become showmen, we would soon have television supported by the public, crude as the results might be. But at present it is too haywire to get far as a merchandising proposition.

Standardization

HERE is marked standardization in the radio offerings of the present season. As with automobiles, so with radio, the various makes closely approach one another in the matter of essential details. However, there is just one more step to take before profitable standardization can be realized, and that is in the matter of components. There are still too many differences in components intended to serve the same purpose. The fussy engineers who insist on splitting hairs, drawing elaborate specifications, and asking for something entirely special when ordering components, are simply adding to the cost and the grief of the radio industry at large, and to the production costs of their employers. Standardize—in components as well as in general design! The automobile industry in this as well as other respects, is a safe guide to follow.

Cutting Heating Time

NOTABLE progress has been made of late by tube manufacturers in the matter of shorter heating time without sacrificing the cherished prerequisites of tube performance and life. Magnesia insulator tubing, introduced almost a year ago, has not only proved ideal material but has permitted a marked reduction in insulator tubing bulk. Some manufacturers are using virtually flat magnesia tubing, with two flat and two round sides, representing about a half reduction in bulk. Others are using tubing notched along one line and even notched along both sides, reducing the bulk by almost half. It becomes possible to produce tubes that heat in ten seconds or less, without sacrificing noiseless operation, long life and other features. And so the quick-heating tube is here at last, not as a trick, not as a clever stunt, but as a regular, common-sense, safe feature.

Tube Tolerances

SERVICEMEN assure us that tubes are not what they used to be. Perhaps so. Perhaps not. We don't know.

But we do know that tubes are being subjected to greater strain than ever before. First, in working voltages. Higher applied voltages certainly place a severe strain on tubes, especially when compared with the lower applied voltages of former days. Secondly, in constant operating time. It is estimated that the average socket-power radio set today operates five hours per day, as compared to three hours a couple of years ago, and an hour or less five years ago. Obviously, tubes are subjected to more wear and tear in a shorter space of time.

Nevertheless, it is our personal belief that the tolerances on some tubes have been materially widened, resulting in poorer average tubes. The public has gained the benefit by way of lower list prices, but we sincerely believe that the radio industry has lost something by way of high-grade average tubes and minimum servicing.

October, 1930

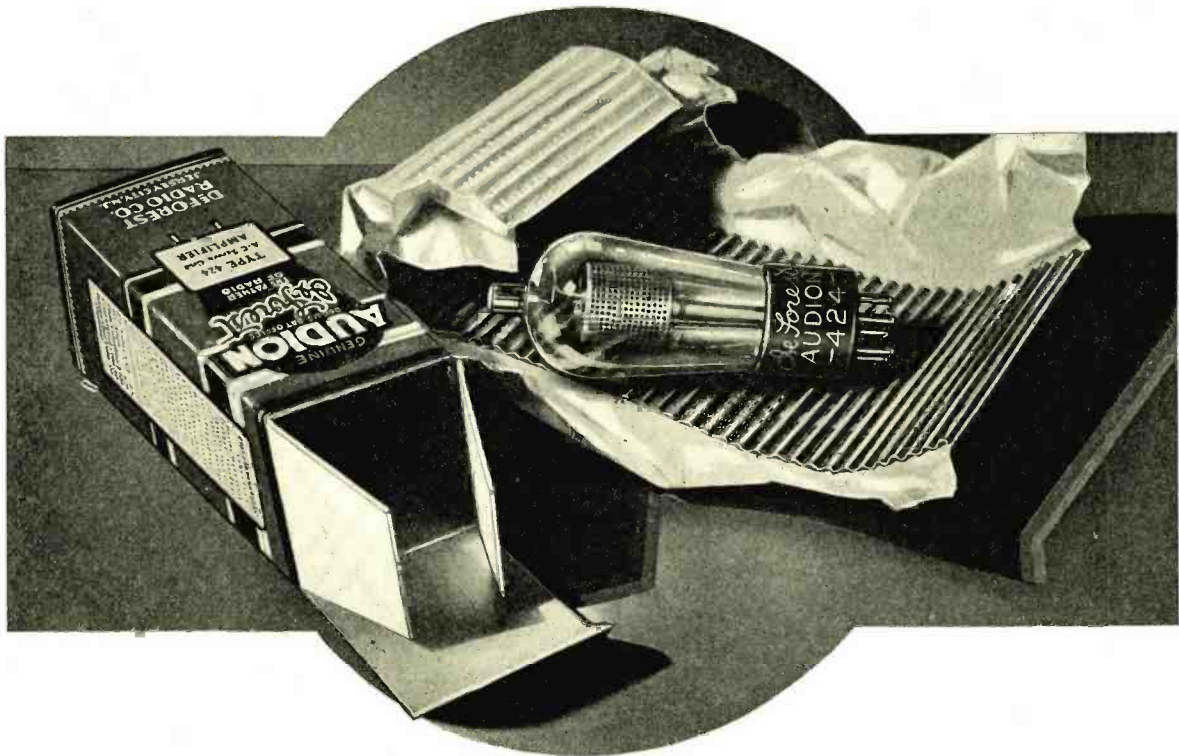

Insure that 1930 Tone!

FOR real success in merchandising and servicing those 1930 sets, you must insure their 1930 performance by placing 1930 tubes in the sockets. Remember, notable improvements have been scored in radio tubes as well as in sets during the past twelve months.

Which is just another way of specifying DeForest Audions, because, when you use these tubes, you are using tubes produced during the past month or two. No danger of tubes from a huge inventory over a year old. No danger of 1929 or even 1928 tubes. The

DeForest organization, operating on a rigidly controlled production schedule, has never been confronted with a huge inventory of rapidly obsolescing tubes *that must be sold.*

The steady, untiring, farseeing pioneering of yesterday, today and tomorrow, *plus* controlled production, insures for DeForest Audions the latest and the best the vacuum tube art has to offer.

Equip those sets with DeForest Audions. Insure that 1930 tone!

DeForest Tubes are approved as standard equipment in Crosley and Brunswick sets

DE FOREST RADIO COMPANY
PASSAIC NEW JERSEY
Export Department: 304 E. 45th Street, New York City, N. Y., U. S. A.

de Forest
(AUDIONS)

RECEIVING
AND
TRANSMITTING

TUBES



— *And Quality is an Engineering Achievement*

THE most successful radio set manufacturers are those whose products give the listener the best broadcast reception. And for perfect reception nothing can take the place of quality in the set.

The perfection of radio—the in-building of quality—is an engineering achievement. It has involved the close co-operation of research engineer, parts manufacturer and set maker.

In this development Scovill is proud to have been a pioneer. Scovill electrical, metallurgical and mechan-

ical engineers, Scovill laboratories, research workers and craftsmen have worked from the beginning of the industry to give the set maker better condensers and metal parts.

Today, Scovill radio condensers are recognized as leaders in quality. Scovill manufacturing service is known for being a step ahead. And Scovill enjoys the patronage of radio's famous manufacturers. If you are one of the few who are not now using Scovill parts there is a representative at the nearest Scovill office who will be glad to talk with you.

SCOVILL 

Established 1802

MANUFACTURING COMPANY

• WATERBURY • CONNECTICUT •

Boston
Atlanta
Chicago

Providence
Cleveland
Los Angeles

New York
Detroit
San Francisco

Philadelphia
Cincinnati

In Europe—The Hague, Holland

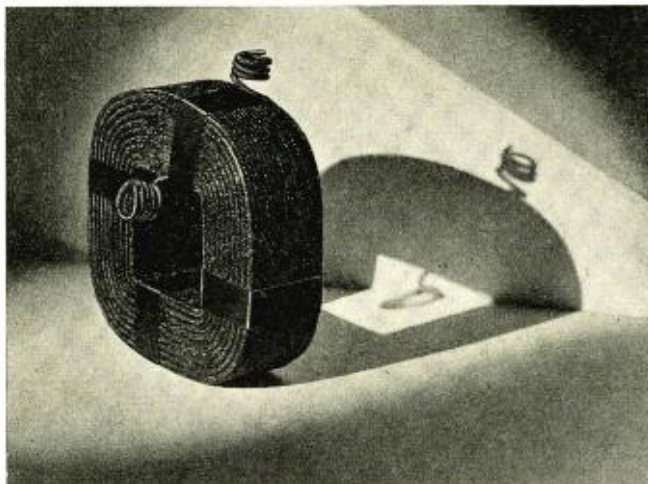

Apply new

KNOWLEDGE

to your present
coil design

Yesterday's most carefully engineered coils may be obsolete today. Constant research establishes new knowledge, new materials — even new fundamentals — which improve the efficiency of today's coils far beyond anything known heretofore.

General Cable, through its extensive research facilities, is responsible for much that is new in coils. It proceeds on the fact that every coil must be separately engineered to fit its specific job.

In the light of the new knowledge developed by this research, General Cable suggests a review, by competent General Cable engineers, of the characteristics of the coils you use in order that the general efficiency of your products may gain through coils modernly designed.

General Cable coil engineers await the opportunity to assist you, with all this experience and facilities.

GENERAL CABLE CORPORATION

EXECUTIVE OFFICES: 420 LEXINGTON AVENUE, NEW YORK • OFFICES IN PRINCIPAL CITIES



An
open letter from the
PRESIDENT
of
GENERAL CABLE
CORPORATION



THESE UNITS WERE OPERATED THROUGH FOUR MAJOR DIVISIONS

DUDLO DIVISION

DUDLO MANUFACTURING COMPANY

ROME DIVISION

ROME WIRE COMPANY
ATLANTIC INSULATED WIRE AND CABLE COMPANY
DETROIT INSULATED WIRE COMPANY
GREAT LAKES THREAD AND YARN COMPANY
ROME ELECTRICAL COMPANY, INC.
SOUTHERN STATES CABLE COMPANY

SAFETY DIVISION

SAFETY CABLE COMPANY
A-A WIRE COMPANY
AMERICAN INSULATED WIRE AND CABLE COMPANY
BALTIMORE COPPER SMELTING AND ROLLING COMPANY
PHILLIPS WIRE COMPANY

STANDARD UNDERGROUND DIVISION

STANDARD UNDERGROUND CABLE COMPANY
PEERLESS INSULATED WIRE AND CABLE COMPANY

GENERAL CABLE



GENERAL CABLE CORPORATION was formed in the latter part of 1927 by five leading wire and cable manufacturers. The objects we hoped to attain in the formation of this company were:

First: The ability to offer a combined improved service covering all types of wires, cables and accessories.

Second: The ultimate lowering of cost of production by well located plants at strategic points, equipped to the best knowledge of the combined companies.

Third: The ability to carry on research and development in the seeking of new, more economical and better types of wires and cables by a large organization which none of the smaller companies was as capable of carrying on.

The operation of General Cable Corporation has been carried on through four Divisions — Dudlo, Rome, Safety and Standard — operating as distinct manufacturing and sales organizations. In order to give our customers better service and to effect certain economies in our organization, I am pleased to announce that on October first, 1930, our Company will function as a single unit — GENERAL CABLE CORPORATION — with a unified policy under a single management.

The sales staffs of the several companies are now one, greatly simplifying your buying contacts.

Billing for all products, regardless of the type or place of manufacture, is now done only in the name of General Cable Corporation; not by the component companies, as heretofore.

Today there are twenty-two General Cable District Offices, one of which is near you. They are manned by competent sales and engineering personnel who are always available and anxious to cooperate with you.

Twelve manufacturing plants provide adequate manufacturing facilities and carry extensive stocks of all kinds of wires and cables. These stocks are supplemented by twelve well located warehouse stocks. The buying of wires and cables is still further simplified for you by widespread electrical wholesaler distribution.

You have been doing business with one or more of the component companies of General Cable Corporation. Under this new plan of operation you will enjoy more complete, effective and prompt service. We shall aim to improve quality and standardize our product continuously.

W. J. ...
President

CORPORATION

General Cable's District Offices

ATLANTA
1526 Healy Building

BIRMINGHAM
1306 Watts Building

BOSTON
89 Broad Street

BUFFALO
56 Clyde Avenue

CHARLOTTE
1503 First National Bank Building

CHICAGO
20 North Wacker Drive

CINCINNATI
920 Chamber of Commerce Building

CLEVELAND
1814 Terminal Tower

DALLAS
1614 Allen Building

DENVER
650 Seventeenth Street

DETROIT
827 Fisher Building

KANSAS CITY
932 Board of Trade Building

LOS ANGELES
939 East Fourth Street

MINNEAPOLIS
109 South Seventh Street

NEW YORK
420 Lexington Avenue

PHILADELPHIA
123 South Broad Street

PITTSBURGH
1714 Koppers Building

ROME, N.Y.
Mill Street

SAN FRANCISCO
465 Tenth Street

SEATTLE
570 First Avenue, South

ST. LOUIS
1213 Ambassador Building

WASHINGTON
704 Wilkins Building



EXECUTIVE OFFICES
NEW YORK: 420 Lexington Avenue

TEXTOLITE LAMINATED TUBING

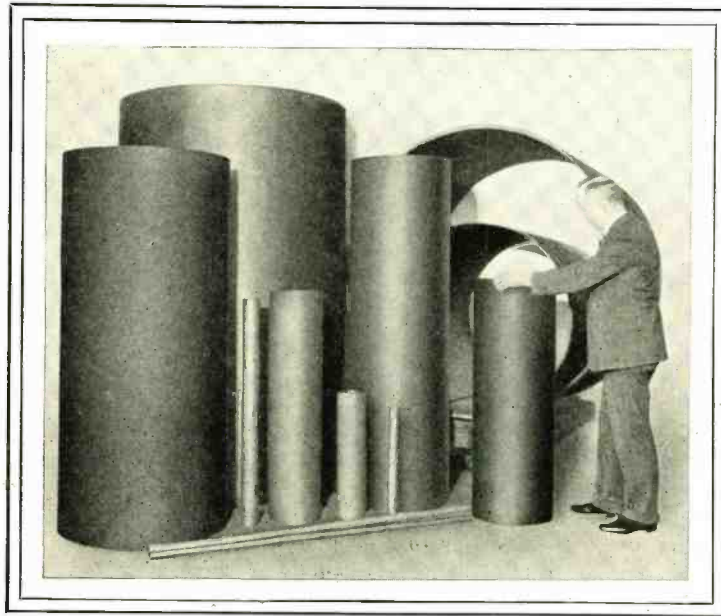

*Manufactured in a convenient range of standard diameters from $\frac{1}{8}$ inch up to 72 inches, and larger for special jobs.
Lengths—up to 100 inches*

IN EVERY SIZE, Textolite tubing is remarkable for strength—both electrical and mechanical—end-to-end uniformity, machinability. These characteristics, combined with the fact that the tubing is furnished in lengths and diameters for every use, qualify this insulating material for your consideration.

Ask your local G-E sales office to tell you how you can use Textolite laminated to advantage or inquire for the advice of the eastern or western fabricators of Textolite laminated:

General Fabricating Co.
165 Greenwich St.
New York City

Electrical Insulation Corp.
308 W. Washington St.
Chicago, Ill.



JOIN US IN THE GENERAL ELECTRIC PROGRAM, BROADCAST EVERY SATURDAY EVENING ON A NATION-WIDE N.B.C. NETWORK

GENERAL ELECTRIC
SALES AND ENGINEERING SERVICE IN PRINCIPAL CITIES

RADIO ENGINEERING

Production, Administration, Engineering, Servicing

October, 1930

Grid-Glow Tubes Now Widely Used in Industrial Applications.

TUBE relays, for a number of years have been known and used to a limited extent—mostly in radio transmission and reception; but, during the past few years, problems involved in the development of talking motion picture and television equipment have incited intensive research, which, in addition to effecting progress on the original problems, has resulted in radical improvements for the existing vacuum tube devices and the invention of new tube relays.

Electrical engineers have realized that recent tube developments have provided them with a new tool having many applications. It will be the purpose of this discussion to point out a few of the recent tube developments and some of their applications.

*Engineer, Westinghouse Electric & Mfg. Co.

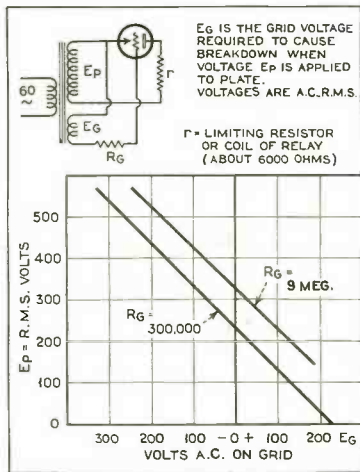

Fig. 1. Typical characteristic curve of cold cathode grid-glow tube.

Electron Tube Relays

By H. B. STEVENS*

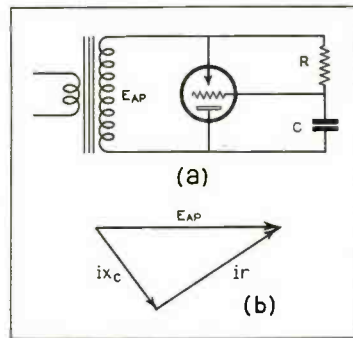

Fig. 2. Control of cold cathode grid-glow tube.

Grid-Glow Tubes

Prominent among recent tube developments has been a grid controlled rectifier known as the "grid-glow tube." This tube, in appearance, is quite similar to the well-known three-electrode amplifier tube and is made to fit the standard UX base. Its operation, however, is somewhat different in that its grid controls the starting of a gaseous discharge.

With a given voltage applied between the anode and cathode, and the grid potential raised to a point where a glow discharge is initiated and the tube becomes conductive, the control grid loses its effect on the operation of the tube. In order to stop the discharge, it is necessary to remove the cathode-anode potential or lower it below the break-off point; i. e., if the device is operated from direct current, the controlled circuit must be opened to stop the flow of current; but, with

Photoelectric Cells and Phototube Amplifiers Have Many Uses in Providing Relay Action.

an a-c. operating potential, the discharge lasts until the conducting half cycle reaches zero and is started again at the beginning of each succeeding cycle. The grid, in this case, can be maintained at a potential that will allow the discharge to continue, or, if the initiating impulse is removed, the glow discharge will stop.

Control over the output current of the glow tube may be had by varying the phase relation between the grid-anode potential and the anode-cathode potential, thereby changing the part of the cycle at which the discharge starts and resulting in a change in the average current flowing in the controlled circuit.

Grid-glow tubes are made with both cold and hot cathodes. The cold cathode tube has no filament—its negative electrode consisting of a metal cylinder, and it has the advantage of always being ready for instantaneous operation. The hot cathode tube, of course, requires a filament which must be heated before the tube is made to pass current. The current that can be carried by a cold cathode tube is

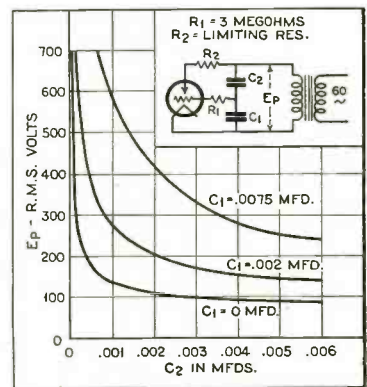

Fig. 3. Typical characteristic curve of hot cathode grid-glow tube.

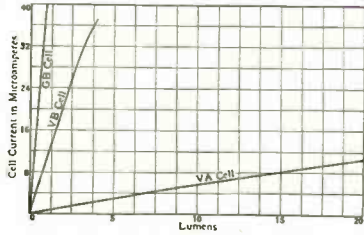

Fig. 6. Typical light sensitivity curve of phototube.

limited, practically, to a few milliamperes while currents of several amperes can be obtained with a hot cathode. The operating characteris-

The characteristics of the hot cathode tube are shown by the typical curve of Fig. 3.

Fig. 4 illustrates a number of grid-controlled rectifier tubes having current ratings of 6 amperes, 0.5 amperes, 100 milliamperes, and 20 milliamperes, respectively.

Photoelectric Cells

Light sensitive devices are not at all new, the old type selenium cell having been used in laboratories for a number of years. They were, however, a bit unstable and unreliable in their operation and have never assumed any considerable importance in a commercial way.

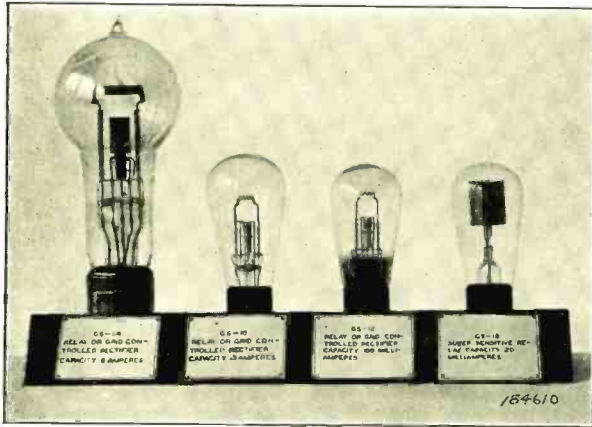

Fig. 4. Range of sizes of grid-glow tubes.

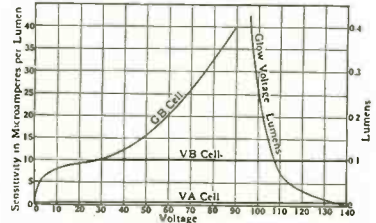

Fig. 7. Typical voltage sensitivity curve of phototube.

tube increases with an increase of voltage and that the sensitivity of the vacuum tube is independent of applied voltage for any voltage above approximately 30 volts.

Typical color sensitivity curves of commercial phototubes are shown in Fig. 8. The color sensitivity of a tube may be changed by a choice of the active element, or by modifying the method of preparation. It is to be noted that the characteristics of the commercial tube have been so chosen that the tube is sensitive near the red end of the spectrum. This type of tube is designed for applications requiring the use of artificial light, and the standard Mazda lamp bulb converts the greater percentage of the energy it receives into radiation near the red end of the spectrum. It is then evident that the characteristics of the commercial phototube especially adapt it for use with a Mazda bulb light source.

The phototube, like most other vacuum tube devices, is a rectifier. For many applications, it is desirable to use a-c. for a phototube and its amplifier. Although the a-c. sensitiv-

ties and circuits of the two types of tubes are practically the same.

Fig. 1 gives a characteristic curve of the cold cathode type tube and the circuit from which it was derived. It is to be noted that grid potentials are referred to the anode.

In practice, the grid-anode potential of the tube may be controlled by a condenser and resistor as shown in Fig. 2. By a proper choice of the capacitance, C, (of the order of 25 mmf.) the resistor, R, need not have a resistance lower than several megohms to cause an operation. Thus, the conductivity of a drop of water or of a flame may furnish the necessary leakage path. Similarly, a very small capacity such as the capacity of the human body may be used in the grid-anode circuit to start a glow discharge in the tube and a consequent operation of a mechanical relay.

The advent of talking movies and experimental work on television necessitated the development of a commercially practical photoelectric cell or "phototube," as it is now being called.

Many metals exhibit photoelectric properties. One type of satisfactory commercial tube utilizes a caesium-oxide coated cathode. The anode consists of a vertical nickel wire.

Fig. 5 illustrates a caesium type photoelectric tube now on the market. This type of tube has the same physical size as the standard UX-199 radio tube.

Phototubes are available in either the gas-filled or vacuum type. The gas-filled tube is somewhat more sensitive, but a trifle less constant for applications requiring a high degree of sensitivity. The vacuum type tube is generally recommended for industrial applications requiring constancy of operation and which must stand a certain amount of abuse.

The cathode of a phototube emits electrons in proportion to the light intensity directed on it, resulting in a corresponding current change as indicated in the typical curve of Fig. 6.

Caution must be exercised in maintaining the applied voltage of the gas-filled type phototube below a certain maximum, otherwise, a glow discharge may be originated which will result in serious damage. An inspection of the curve of Fig. 7 will show that the sensitivity of the gas-filled

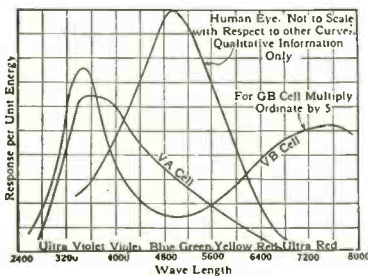

Fig. 8. Typical color sensitivity curve of phototube.



Fig. 5. Typical commercial phototube.

ity is somewhat less than the d-c., the scheme is quite applicable in many cases.

Phototube Amplifiers

The current passed by a phototube is generally far too small to actuate a rugged mechanical relay, or even produce a satisfactory meter reading for most purposes. This minute current, however, may be utilized to actuate an amplifier tube which in turn performs the desired operation. The grid-glow tube or an electrode thermionic vacuum tube may be used. Use of the grid-glow tube results in a very simple light relay for applications requiring only an indication of total light or total darkness (i. e., within reasonable limits), while a three-electrode thermionic tube is necessary when an indication of varying degrees of light intensity is required.

A single grid-glow tube or other amplifier tube provides sufficient amplification for many applications requiring

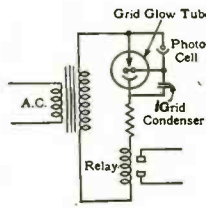

Fig. 9. Phototube and grid-glow tube connected for operation when photo cell is light.

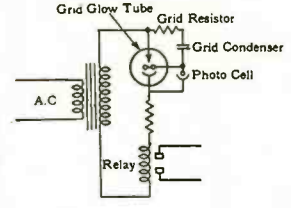

Fig. 10. Phototube and grid-glow tube connected for operation when photo cell is dark.

tube maintains the grid at a potential less than the operating point until the light is interrupted.

In order to obtain an indication of the intensity of light on the phototube, it is necessary to produce an amplifier plate current proportional to the photoelectric current at all times. This procedure requires a resistance-coupled amplifier such as would be used to amplify a direct current. The impedance of a phototube is quite large compared to that of many vacuum tubes—of the order of a hun-

Applications

Fig. 14 illustrates a device that has been built to show how the phototube may be utilized in connection with a sorting device. Small packages wrapped in tinfoil with paper labels are placed on a conveyor belt and passed under a concentrated light beam. A tinfoil surface reflects a sufficient amount of light to the light-sensitive tube to cause an operation resulting in the package being discarded. The surface of a paper label absorbs light to such an extent that the phototube is not sufficiently lighted to cause an operation. Thus, improperly labelled packages are automatically sorted while properly labeled packages are passed.

Phototubes and their auxiliary amplifiers are also being applied to detect and record smoke, to turn on sign lights when darkness falls and to switch them off when daylight comes, to measure concentration of liquids for manufacturing operations, and to count items in mass production by interruption of a light beam. Many other applications are under consideration and will doubtless be made as

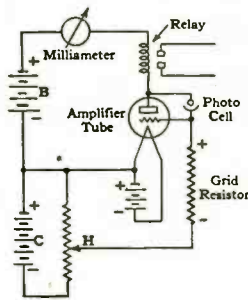

Fig. 11. Phototube and three-electrode amplifier tube connected for increase in plate current with an increase in light.

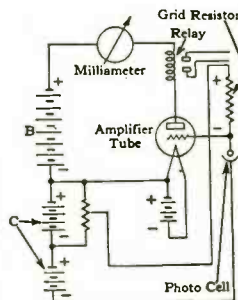

Fig. 12. Phototube and three-electrode amplifier tube connected for decrease in plate current with an increase in light.

a relay operation. Either type of amplifier may be so connected that an increase in light (and a corresponding increase in phototube current) will cause an increase or decrease in the amplifier output.

If a phototube is connected between the grid and anode of a grid-glow tube (see Fig. 9), an increase in photoelectric current caused by an increase in light will cause the grid to become more positive and thus initiate the operation of the glow tube. If, however the light sensitive tube is connected between the grid and cathode, (see Fig. 10) current flow in the photo-

dred megohms. The amplifier grid resistor should have a resistance of from 50 to 200 megohms to match the high impedance of the light sensitive tube.

The amplifier is so connected that the minute phototube current is drawn through the high resistance grid leak producing an appreciable drop which is used to change the bias of the amplifier tube causing a corresponding increment in plate current. The grid leak and phototube may be connected as in Fig. 11 to reduce the bias causing an increase in plate current with an increase of light; or as in Fig. 12 to increase the bias causing a decrease in plate current with an increase of light.

It may be seen from this discussion that if an amplifier tube is used which draws a relatively high grid current, a drop is produced across the grid leak which is of the same order as the drop produced by the phototube, resulting in poor operation or no indication of photoelectric current at all.

Since the phototube is a rectifying device, an amplifier scheme may be used applying "raw" a-c. to the phototube and its amplifier as shown in Fig. 13. The operation of this circuit is essentially the same as for direct current with the exception that current flows only during half of each cycle.

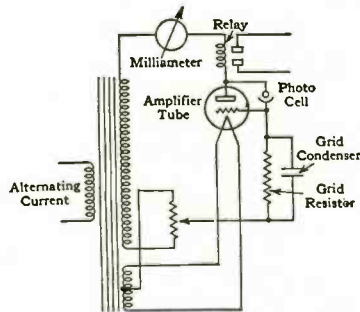

Fig. 13. Phototube and three-electrode amplifier tube connected directly to alternating-current source.



Fig. 14. Sorting small packages for imperfect labels by means of photoelectric tube.

soon as the details for the particular application are completed.

From present indications it seems that these vacuum tube devices will soon assume a position in electrical engineering practice comparable with that now held by a host of other electrical devices in everyday use by industrial concerns.

The writer wishes to acknowledge the aid of Messrs. D. D. Knowles and S. P. Sashoff and Dr. E. D. Wilson in the preparation of this paper.

A-C. Voltage Found to Vary Greatly in Different Localities

By H. G. Cisin, M.E.

SEVERAL months ago, at the suggestion of a group of leading radio manufacturers, the writer started to gather data on a-c. voltage conditions in various parts of the United States. In this work, he was fortunate in obtaining the generous cooperation of well-known radio editors and he was also helped by technically inclined radio fans in numerous localities.

The voltage survey is now completed and the information obtained is certain to prove extremely interesting and useful to everyone engaged in the radio industry. The authentic data obtained, should be especially valuable to manufacturers of electric radio sets, since these manufacturers must recognize the fact that the assumption of a non-fluctuating, standardized value voltage anywhere and everywhere, is a dangerous fallacy. Progressive radio manufacturers are anxious to give set users perfect reception under all voltage conditions and the present comprehensive survey will undoubtedly lead to the universal installation of automatic line voltage control devices in all a-c. radio receivers.

In fact, a device which will provide means for accurately regulating line voltage fluctuations and which will do this automatically, is an imperative necessity with many types of electrical apparatus, but especially so with the electric radio set, which operates most favorably within definite voltage limits.

An inspection of the tabulated a-c. voltage data, reveals some very important facts. Returns were received from representative localities all the way from New York to California and from Florida to Canada. Standard power house rated voltages were found to vary from 105 to 125 volts and in most cases wide fluctuations from the rated or standard voltages were noted to be the rule rather than the exception. In Houston, Texas, a 15 per cent fluctuation above and below the rated 110 volts was reported, giving a total fluctuation of thirty per cent. In many other cities, as much and even more variation was noted. It was generally found that during the evening, when the lighting load was heaviest, under-voltage was experienced. In the day-time and late at night, over-voltage caused the trouble.

Fifty-eight per cent of the radio editors supplying data for this survey, complained of trouble in their own electric radio sets, due to voltage fluctuations. Sixty-one per cent stated that their readers had written letters to them, complaining about unsatisfactory voltage conditions. The radio editors were practically unanimous in the opinion that set manufacturers should provide means for accurately regulating line voltage fluctuations, automatically. This is shown in the last column (No. 3) of the tabulated data. As may be noted, several editors stressed their opinions regarding the necessity of voltage control, by add-

ing "By all means," "A great advantage," "Emphatically."

Radio editors, with their technical knowledge and their long experience in radio work, have realized for some time that automatic line voltage control is the logical answer to electric set

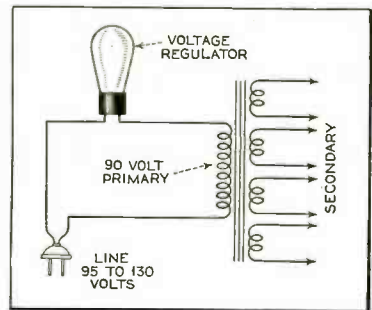

Fig. 2. Showing how the Amperite is connected in the primary circuit of the power transformer.

troubles due to voltage fluctuations and to differing voltages in different localities. In fact, in some towns (not listed in the accompanying table) the rated voltage is as low as 100 volts, while in others it is as high as 130 volts and a line fluctuation of 30 per cent in addition is not considered unusual any place. It is obvious that no radio set could possibly be designed to function correctly over so wide a range. The best designed set and the highest quality tubes can perform efficiently only within a range of plus or minus 5 per cent of their rated specifications. This is shown graphically in Fig. 1, where the shaded area indicates the range which is maintained by an efficient automatic line voltage control.

A glance at this illustration shows that between 5 volts and 15 volts of over-voltage will result in tube burn-outs, tone distortion, blasting, power pack breakdowns, tube noises and lack of selectivity. On the other hand, between 5 volts and 15 volts of under-voltage will cause fading, diminished volume, loss of power and sensitivity, tube failure due to filament crystal-

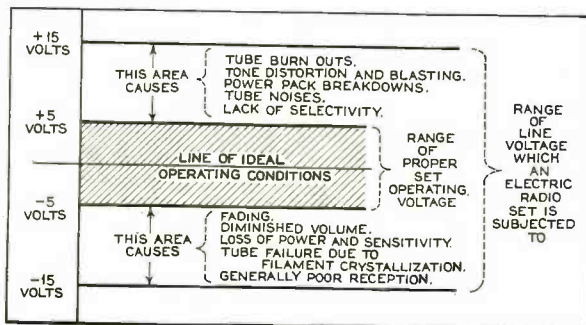

Fig. 1. Chart showing graphically why electric radio receivers require line voltage control. The shaded area shows the range which is maintained by an Amperite, irrespective of line voltage variations.

lization and generally poor reception.

Fortunately, this entire problem has been solved most adequately through the development of a simple device, which is able to handle a line fluctuation of about 35 volts and to regulate the current (or voltage) to a constancy of 10 per cent over the range of this fluctuation. Fig. 2 shows how this device can be provided for in the transformer primary circuit.

Many of the newer, well-known radio sets are now factory-equipped for these new accessories. In these sets, the transformer primary is wound so that it reads 95 volts with the tube voltages at the desired maximum. For example, with one of these devices, the Amperite, in the circuit, the filament voltage of a —27 type tube should read 2.5 volts when the primary is 95 volts. The number of turns in each secondary winding remains the same as the customary 110-115 volt primary and no other changes are necessary.

Owners of electric sets which are not yet equipped with an automatic line

voltage control, can also install an Amperite in their receivers, with the greatest of ease. The only tool required is a screwdriver and nothing in the set needs to be touched. A standard UX-type socket is connected in series with the power supply line, being mounted at any convenient point within the console or cabinet. The proper Amperite is inserted in the socket and the set is then ready for operation. This information will be of great interest to service departments, as it provides a means for overcoming line voltage troubles in sets now in use.

There are many improved features incorporated in the construction of the new line control. The filament structure is continuously wound on re-enforced supports, producing a construction which is extremely strong and practically unbreakable. The bulbs are of standard radio tube size and are neatly frosted to distinguish them from ordinary tubes. The new Amperites operate at lower temperatures, varying in voltage between 10 to 30

volts. Practically, this means that the voltage drop across the unit will increase 200 per cent with a current increase of only 10 per cent.

In concluding this resume of the investigation of a-c. line voltage conditions, it would be unfair not to acknowledge the splendid assistance rendered by radio fans, electrical engineers, servicemen and radio dealers in all sections of the country. During the period of the voltage survey, hundreds of letters were received commenting upon the necessity for voltage regulation in connection with electric radio sets, and complaining about poor reception due to local line voltage fluctuations. In a number of cases, the fans were inclined to place the blame for widely varying voltages upon the local power companies. However, the radio industry must recognize the fact that adequate automatic line voltage control is for the present its own affair and it can now solve this problem to the satisfaction of all concerned.

DATA ON A-C. VOLTAGE CONDITIONS OBTAINED THROUGH THE COOPERATION OF RADIO EDITORS

Following questions also answered by each editor:

1. In the operation of your own electric radio receiver, have you ever noticed fluctuations of voltage sufficient to account for under-volume, fading, sudden blasts or over-volume, tube burnouts and distortion?
2. Have your readers ever written to you complaining of unsatisfactory voltage conditions, premature tube burnouts, etc.?
3. Should set manufacturers, in your opinion, provide means for accurately regulating line voltage fluctuations, automatically?

City	State	A-C rated voltage	Answers of local radio editors to three questions listed above		
			1	2	3
Baltimore	Maryland	120	No	No	Yes
Bridgeport	Connecticut	110	Yes	Yes	Yes
Buffalo	New York	105-120	Not excessively	No	Yes
Chicago	Illinois	110-118	No	Yes	Yes
Erie	Pennsylvania	110	No	No	Yes
Hollywood	California	110-220	No	No	Yes
Houston	Texas	110	15% variation	Dealers	Yes
Indianapolis	Indiana	105-115	Yes	Yes	Yes
Indianapolis	Indiana	110 down	Yes, under-voltage	Yes	Yes
Indianapolis	Indiana	110 up	Yes	Few	Yes, by all means
New York	New York	110-115	Yes	Yes	Yes
Paterson	New Jersey	110	No	Yes	Yes
Philadelphia	Pennsylvania	110-115	Slight	Few	Yes
Pittsburgh	Pennsylvania	110-115	No	Seldom	Yes
Portland	Oregon	110	No	No	Yes
Reno	Nevada	113-118	Not often	No	Yes, great advantage
Richmond	Virginia	110	Little	Some	Yes
San Antonio	Texas	120	Slightly	Yes	By all means
San Francisco	California	115	No	Yes	Yes
Schenectady	New York	Up to 125	Yes	Yes	Yes
Schenectady	New York	110 up	No	Yes	Yes
Sioux Falls	South Dakota	110-115	Yes	Yes	Yes
Springfield	Massachusetts	110	No	No	Yes
Tampa	Florida	110 and 220	Yes, under-voltage	Yes	Yes
Terre Haute	Indiana	110	Yes	Yes	Yes
Topeka	Kansas	110	Yes	No	Yes
Topeka	Kansas	110	Yes	Yes	Yes
Topeka	Kansas	110	No	No	Yes
Wichita	Kansas	110	No	No	Yes
Wichita	Kansas	110-115	No	No	Yes
Wilmington	Delaware	110-115	No	No	Yes
Worcester	Massachusetts	110	No	No	Yes
Worcester	Massachusetts	110	Yes	No	Yes
Youngstown	Ohio	110-115	Rarely	Yes, occasionally	Yes
Youngstown	Ohio	110-115	Yes	Yes	Emphatically yes
Toronto	Canada	115-220 and up	Yes	Yes	Yes

Note: Where cities appear more than once in the above table, reports were received from more than one local publication.

Practical Laboratory Oscillators

Construction and Operation of Various Types of Oscillators Suitable for Many Purposes in the Engineer's and Serviceman's Laboratory

By A. Binneweg, Jr.

SINCE a large proportion of measurements and tests at radio frequencies require an oscillator, the engineer and the serviceman will find the following discussion of the construction, adjustment and operation of oscillator types of unusual interest. Measurements and tests of all kinds require greater precision today than ever before. There are many factors which enter into the proper design of laboratory oscillators which make for better precision, greater facility in operation and a more nearly constant frequency output. These factors, as well as the constructional details of some excellent oscillators, are discussed.

All oscillating circuits are the same in principle, but differ in their practical advantages. For example, Fig. 1 shows the simple changes necessary to convert an ordinary tickler-coil regenerative circuit into a practical Hartley oscill-

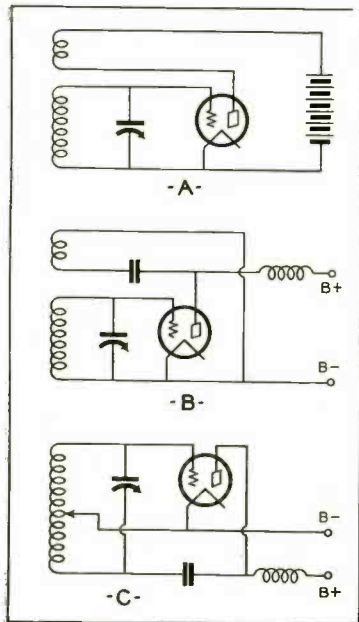

Fig. 1. Showing step-by-step derivation of a practical Hartley oscillator from a simple tickler arrangement.

lator. "A" shows the simple tickler circuit which, of course, would not ordinarily be used for laboratory or experimental use, although it has many practical advantages. By a slight circuit change and the addition of a blocking condenser (to prevent short-circuiting the plate supply), Fig. 1B results. Note that one end of each of the coils is connected to the same point on the filament; both coils connected together. By combining the two coils into a single one, and shifting one end of the condenser, so as to include the whole inductance in the oscillating circuit, Fig. 1C results. The filament lead is provided with a clip (for fine adjustment—usually sufficient to provide a permanent connection at the coil's electrical center). If the variable condenser is connected across the entire coil, the turns in the inductance must be reduced, for the same condenser setting, if the frequency is to remain constant.

Adjustment of Circuits

None of the oscillator circuits described here are particularly difficult to adjust; one usually has only to connect up the parts and the set operates immediately. However, there are certain practical points that will help.

The Hartley circuits of Fig. 2 will supply strong oscillations if the filament tap is connected at the electrical center of the winding, although a few turns either side of center will make little difference. The oscillation strength decreases as the filament-tap is moved away from the center of the

winding, either way. In certain tests, requiring good waveform, it may be to advantage to include less turns in the coil between filament tap and grid end of the coil (i.e. less turns in the grid coil).

Since most broadcast receivers are intended to be non-regenerative, it is necessary to employ a modulated oscillator if the signal is to be heard. It will be found, in general, that an oscillator with grid condenser and leak of the proper values, will be modulated. The filament-tap connection normally goes to negative filament, if batteries are employed; if a-c. is used to supply the filament (especially desirable if power tubes employing large filament currents are used), the return should be to filament center-tap, although, in certain cases, it may be desirable to shunt a potentiometer across the filament, with the filament-clip lead con-

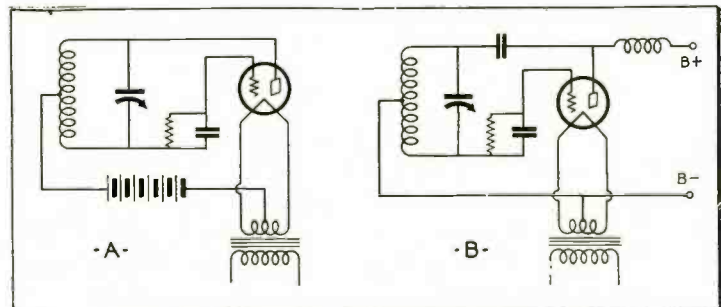

Fig. 2. Hartley circuits for laboratory use. The circuit of A requires no choke coils.

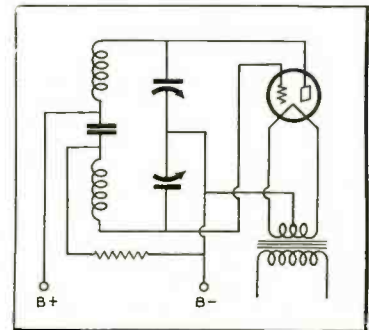

Fig. 3. Colpitts circuit which gives good results for laboratory use. It requires no choke coils.

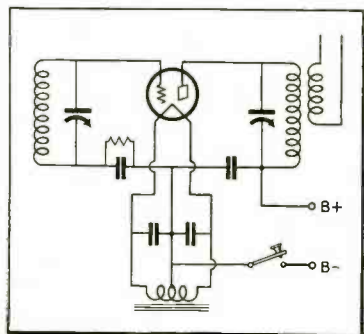

Fig. 4. Tuned plate-tuned grid circuit. This circuit is used extensively in short-wave transmitters.

nected to the movable arm. Some control on the modulation is thus provided, either for clearing up the signal or providing a slight modulation. A simple oscillator can also be modulated by employing an a.c. plate supply. This type of modulation, however, is low-pitched and not suitable where various other frequencies are also to be employed.

Where definite modulation frequencies are necessary, a separate audio oscillator should be employed. Where only one modulation frequency is desired (for example 1000 cycles) a grid condenser and leak of the proper values can be used. There are oscillator connections in which the tube can oscillate at audio and radio frequencies simultaneously, but these are usually complicated in comparison.

The Colpitts Circuit

The "Colpitts" circuit (Fig. 3) has certain advantages as well as disadvantages. The main oscillating-circuit inductance is divided into two equal windings with a condenser (having a rating about twice the peak plate voltage) between. This condenser (the larger the better) should run around .01 mf.; otherwise, at low frequencies, the oscillation strength will be decreased. A double-unit condenser is required for this circuit; the minimum capacity (about 20 mmf. for a .00035 condenser) is halved by the series connection, which is an advantage at short waves. Both condenser rotors (in other oscillator connections there will be "hand-capacity" unless shielding is employed) are at ground potential; thus shielding is not necessary although of advantage for reducing direct pickup between oscillator and test apparatus.

This circuit will oscillate well at the highest frequencies, if the leads are short. The tuned plate-tuned grid circuit of Fig. 4 (two controls) is also good in this respect. The Hartley is not as good at high frequencies, but can be improved, somewhat, by employing a choke or fixed condenser in the filament-clip lead. The adjustment of the filament clip is difficult when the total turns in the inductance are small. The Hartley may work better without the clip at the higher fre-

quencies; if a small switch is connected in the center-tap lead, the clip lead can be opened.

The tuned plate-tuned grid circuit is a favorite for transmitting purposes. Its disadvantage is that two controls are necessary and thus close calibration is impossible. At high frequencies, the grid and plate controls have about the same effect on frequency adjustment. However, it is a persistent oscillator and, where accurate calibration is not necessary, it has advantages. Both dial settings are normally the same or nearly so; thus it is impossible to arrange two condensers on the same shaft with a vernier for one of them. In precise measurements, the calibration of the usual laboratory oscillator cannot be relied upon, anyway, at high frequencies. Especially is this true if different types of tubes are to be used, so that the frequency values are

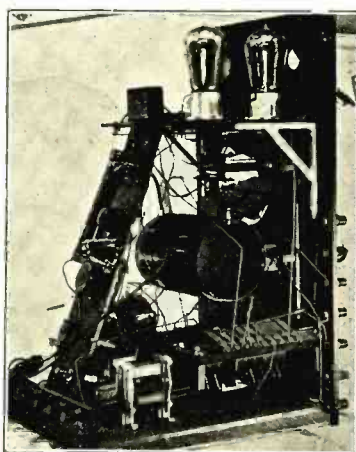

Fig. 6. Amateur transmitter revamped for laboratory use. Power outputs up to 10 watts are obtained.

measured. If such is the case, the tuned plate-tuned grid circuit will serve very well.

It is simple to get in operation. Simply turn on the power and adjust both condensers to the same setting (both coils assumed electrically

matched). As the proper setting for either condenser is approached, there will be an abrupt decrease in plate current, usually, which is at a minimum for best operating conditions.

For some laboratory work, a resonance indicator is not necessary. However, for general use, a sensitive resonance indicator should be included. A plate milliammeter can be used for this purpose but it is, in general, not as sensitive as a grid meter. Under certain conditions, the change in plate current, when the oscillator is tuned into resonance with an external circuit, may be quite small, or negligible, while the change in grid current is a good indication of resonance of oscillation. Extremely small grid currents are ordinarily obtained, but when the tube starts to oscillate, swinging to the positive part of the cycle, a rectified grid current will flow, indicating oscillation.

Only the positive part of the high-frequency cycle will be effective in causing grid current so that the grid current will consist of radio-frequency "pulses." The grid milliammeter will assume an average d-c. value. The grid bias in volts will be the average d-c. current as read by the instrument (amperes) multiplied by the value of the grid leak resistance in ohms. The value of grid leak resistance used will influence the electrical efficiency of an oscillator arrangement but, often, efficiency is not a prime consideration so that lower grid leak values may be employed to reduce the grid bias, raising the grid current to a value easily read on available meters.

Grid Meter Sensitive

The advantage in sensitivity of a grid-meter connection over a plate meter is in general well worthwhile. It is perhaps safe to say that a grid-meter is in general about three times as sensitive; that is, when an external circuit is tuned to the frequency of the oscillator, the change in deflection of a grid-meter will be about three times that occurring in a plate meter. This, however, is not always the case.

When a tube oscillates, a certain value of grid current is obtained de-

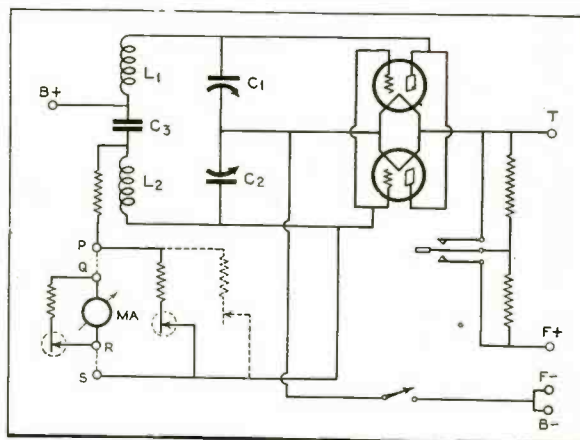

Fig. 5. Circuit diagram of a complete laboratory oscillator arrangement.

pending upon particular circuit conditions. Any condition which reduces the radio-frequency circulating current in the oscillating circuit, will also reduce the r-f. voltage and grid current. A poor choke coil, for this reason, will reduce the grid current.

Chokes for use in an oscillator can be tested by noting the grid current obtained. Curves can be run using a series-fed Hartley arrangement, requiring no choke, thus obtaining a curve of grid-current as the function of frequency when no choke is used. Then, by a simple change, the circuit can be changed to shunt feed, requiring a choke, and similar curves run. The "theoretical" curve obtained with no choke will be approached by a good one, but there is always some loss, so the grid current, in general, will be less. If the grid current sud-

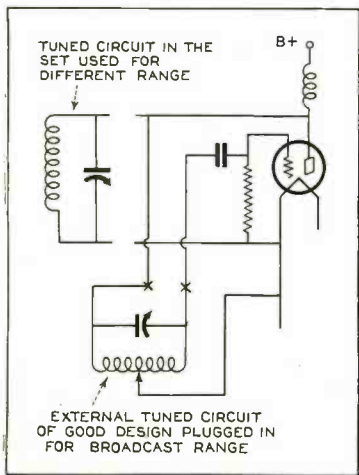

Fig. 7. If the tuned circuit in the set does not cover the proper range a new tuned circuit can be plugged in readily.

denly drops, when the dial is operated over a given frequency range, it is likely that the choke coil in the oscillator is resonant at that frequency.

It is convenient, sometimes, to provide a single oscillator with means so that different sizes of tubes may be used. As shown in Fig. 5, two rheostats in series with a s.p.d.t. switch can be used to give the proper filament voltages for any tube used. A carbon-pile rheostat will serve for tubes of low filament currents while a 2-ohm size is used for power tubes. Either of the rheostats can be shorted out by the switch. A filament voltmeter is usually not necessary, but if a post is provided on the panel, the filament voltage at the tube's terminal can be read when necessary.

A low-power oscillator can usually be mounted, entirely, on a 7 x 12 panel. A Radiola 111-A cabinet can be used for a case. For an oscillator like Fig. 5, the coils can be wound on 3-inch bakelite tubing forms, 4½ inches long. Each coil is provided with four plugs. Both sections of the oscillator inductor are of the same number of

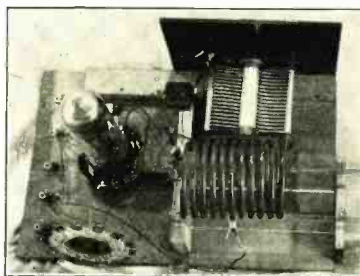

Fig. 8. A 50-watt short-wave laboratory oscillator. Certain tests require more power.

turns. If a .00035 condenser is used, the number of turns in each section, the corresponding wavelength ranges will be approximately as follows:

No. of Turns	Wire Size (Meters)	Range
2	16	11-30
5	16	25-66
13	16	53-150
33	22	135-375
74 (Bankwound)	22	315-800

Ample overlap is provided for a good continuous calibration. Other sizes can be used as desired.

Direct current is better for plate supply, and can be supplied by batteries or a generator, but rectified and well-filtered a-c. will serve. An unsteady plate supply will usually cause frequency shifts; troublesome for accurate work. If a-c. is used, a large choke in series with the plate supply will smooth out possible low-frequency "drifting" of the galvanometer needle in the test circuits. A-C. can be used as filament supply. Slow-heating filaments will give very little modulation on the oscillator output.

One can often procure an oscillator already assembled from an experimenter who has no further use for it. These are often of high grade and can easily be modified or modernized, if an old model, for laboratory use. The oscillator shown in Fig. 6 was formerly a "c.w.—i.c.w.—phone" transmitter. It serves very well as a modulated oscillator. Usually the inductance will be too small for operation in the broadcast range, but can be used "as is" at short waves, so a larger size must be employed. Such a tuned circuit, covering the proper frequency range, can be plugged in easily as shown in Fig. 7. Fairly long leads are not of importance at low fre-

quencies, although the radiation is greater.

About the only differences between an old model transmitter and the latest types are the L/C ratio used and the sizes of blocking condensers. In some types, both a ground and counterpoise were employed. In others, no plate-blocking condenser was used in the Hartley circuit. Any changes can easily be made to any of the circuits suggested here, if the circuit in the old set is carefully traced first.

The oscillator of Fig. 8 has many novel features. Its power is greater so that it can be used, for example, to measure r-f. resistance. If an oscillator of small power is used for such purposes, the coupling to the circuit under test must be comparatively large, ordinarily, to secure the requisite meter deflections, thus there is danger of reflection effects which influence the results. With higher power the coupling can be reduced, and greater accuracy obtained. At higher power, a double-spaced condenser is necessary in the oscillating circuit. Even when used line changes may cause temporary sparking between plates. The block-

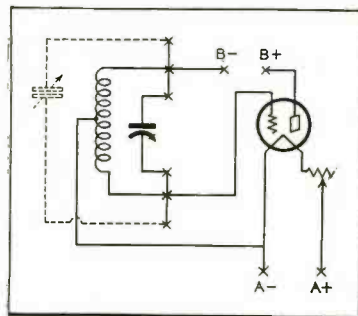

Fig. 9. The simplest oscillator. A minimum of apparatus is required.

ing condensers must withstand the higher voltages and the grid leak should preferably be heavy-duty (10,000 ohms will usually serve). All leads in the oscillating circuit proper must be heavy.

Fig. 8 shows a convenient arrangement. All plate and filament supply posts are mounted on the baseboard. The copper tubing inductance is mounted on a pair of plate-glass supports which can be moved out, if desired, to make room for a coupling coil. The glass plates are fitted into slots cut in the wooden uprights which are screwed to the baseboard. By

(Concluded on page 42)

Fig. 10. A 100-watt short-wave transmitter designed by the author for the Borden Field Arctic Expedition, K G E G. Note how proper coupling between antenna and oscillator coils is conveniently obtained.

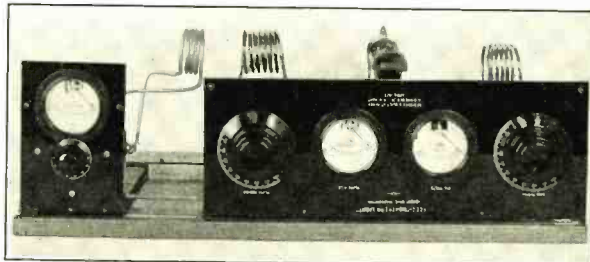

Speaking About That 1930-31 Production

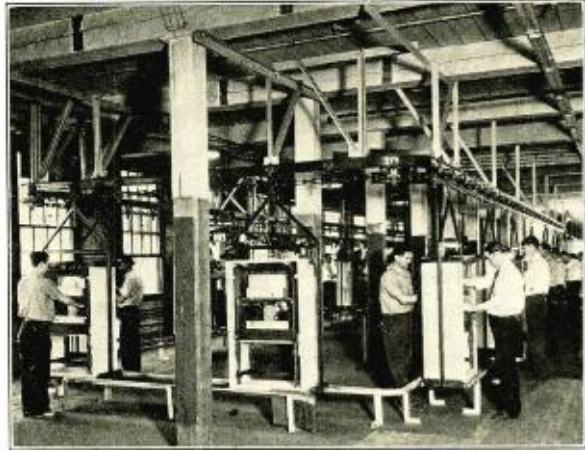

Overhead conveyor assembly line in plant "B" of American Bosch Magneto Corporation facilitates production and insures greater uniformity

BY AUSTIN C. LESCARBOURA
Mem. I. R. E., Mem. A. I. E. E.

WHEN will radio production really get under way again? And when it does, what will the industry produce? And when it produces, how will it dispose of its wares?

Such questions, with their variations and embellishments, are being asked in great confusion these days. And why not? As these lines are being written, the season's production activities have not gained much headway, which is a distinctly new experience in the heretofore optimistic radio industry. Ever since April, production schedules have been postponed month after month, until parts and materials purveyors have all but despaired of ever having a market once more for their wares. Meanwhile, surplus production of the past season has been slow to find buyers, but desperate liquidation measures have left jobbers and dealers with little on hand to sell. And so a new flood of radio products must now come from the radio plants. Present-day abnormal conditions in the industry make for many rumors. Our industry is, of course, one which delights in rumors. Stories of this company or that company are launched almost hourly. The favorite brand of stories these days is that dealing with the bankruptcy or threatened bankruptcy of this company or that. One large company is scheduled to fail month after month, and yet, somehow, it fails to fail. Instead, it springs an entirely new surprise on the industry and pushes ahead to bigger and better business, year after year. All in all, these rumors are a serious handicap. Even though the industry sees fit to support at least one publication that capitalizes on the rumors, gossip, scandal, financial trouble and other such news without constructive interpretation, the fact remains that less

talk and more forward-looking measures would go far towards increasing the profits and dividends.

All of which is by way of introducing the results of a survey recently conducted among radio set and parts manufacturers, for the purpose of obtaining some light on the production situation for the 1930-31 season. Fed up on rumors, we decided to go out and dig up our own facts, which, properly digested and interpreted, are presented in what follows.

A New Survey

The first point which most of us would like to know is just this: How many sets will be produced during the

In Which We Survey the Radio Manufacturing Situation and Learn What Is Being Planned for the Next Twelve Months

1930-31 season? Placing that question before the radio manufacturers, we obtain an interesting range of figures. That optimism still reigns supreme, despite recent storms, is evident from the fact that some estimates run as high as 4,500,000, or just about equaling the peak production of the past. However, the more conservative manufacturers—and, strangely enough, the big fellows generally talk the smallest figures—estimate this year's total production at about 2,500,000 to 3,000,000 sets. Some guess as low as 2,000,000.

It is interesting to note that the total is broken down into the various types of radio sets as follows:

Of the a-c. type, the estimates average between 2,000,000 and 2,250,000 sets, or, in terms of percentage, around

90 per cent for the total production. Of battery-operated sets, there seems to be a wide range of opinion, the estimates averaging from 250,000 to 500,000 sets, or 5 to 10 per cent, with one prominent manufacturer of tubes placing his estimate at 650,000 battery-type sets, and one set manufacturer at 750,000, no doubt based on the engineering developments of prominent battery manufacturers by way of satisfactory and economical battery sets. The d-c. socket-power receivers are estimated at no more than 10 per cent, or perhaps 250,000 or less.

As for cabinet types, the a-c. console leads by a wide margin. The table type amounts to 5 per cent or less, since it has been found possible to produce cabinet types of attractive design at very low cost. The compact or so-called mantlepiece set is mentioned by some manufacturers as a big factor in this season's market, although this type is taken seriously only as we move towards the Pacific. One manufacturer in Utah places the mantlepiece set production at 500,000 for this season, but since he caters largely to the West Coast trade, where the mantlepiece radio is a native production, he is perhaps moved by a Pacific Coast complex.

Two-Receiver Homes

Production, of course, should be based on the potential market. It is useless, as we have learned from the sad experience of the past, to keep on producing without regard for the purchasing power and dictates of the public. In seeking a larger radio market at this time, we have ventured to suggest a "second set" campaign, or selling the idea of additional sets in the average home, as a means of increasing radio set sales. Most manufacturers appear to react favorably to this idea, and look to the mantlepiece set as the logical second set in the average home.

Of greater concern to most manufacturers than selling a second set to

the average home is the problem of trade-ins. During the past year or two, the trade-in has become a factor in radio merchandising circles, although dealers, through bitter experience, have learned to allow very little on trade-ins, irrespective of potential worth, thereby being in position to dispose of the old sets even as junk, if necessary. However, it is a mooted question whether to attempt to build up a market for the trade-ins as seconds in the home, especially for the use of the boy or the experimentally inclined daddy or even the servants, or still again whether the old sets should be given to poor families or institutions, on the one hand, or if it would not be better policy not to push trade-ins but rather foster the sale of new second sets. Our personal opinion inclines toward letting the trade-ins take care of themselves, which they seem to be doing with the better kind of merchandisers, while pushing the cheaper grade of set as the second set.

The second set is largely a matter of price and the size of the home. Apartment house dwellers are not in-

E. R. FARNY SAYS

E. R. Farny of All American Mohawk says: "The radio industry may be improved by establishing Uniform Credits and by the organization and establishment of a real patent pool."

terested in a second set. Neither is the bungalow occupant. However, there are millions of homes, even of the modest sort, which might well take a second set, provided that second set sells at a low figure. Many manufacturers feel that an intensive advertising campaign, preferably of the institutional kind without reference to any particular brand, perhaps supported by publicity, would go far towards cultivating the potential second set market.

Production Capacity

Having placed the total 1930-31 radio market at between 2,500,000 and 3,500,000 radio sets, the next proposition is to determine what is going to be done with the surplus production capacity of the radio industry. While there are no figures available as to how many radio sets the industry can produce, and this means also the detail manufacture of components, we estimate the production capacity at better than 10,000,000. One authority states that our peak capacity, before the recent crash, was 25,000,000 sets per year! At any rate, it is patent that the radio industry cannot pay attractive dividends with a production reduced to a couple of million radio sets. What to do?

The opinion is pretty generally divided in the matter of diversified production. Some manufacturers feel that theirs is a radio business, pure and simple, and radio it shall remain.

They are going to make a living at radio or go bust. Others feel that the industry is geared much too high for present and future demands, and that, therefore, other products must be produced if the large plants are to be kept intact. Still others point out that radio is decidedly seasonal, all efforts to the contrary notwithstanding, and insist that other lines are essential to level up the production curve.

Side Lines

The electric-refrigerator is now well-launched by some radio manufacturers as the alternate line. However, this is looked upon as the forerunner of a large line of household appliances. Most radio manufacturers are ideally set up for the production of small mechanical and electrical parts as well as the most intricate kind of assembly. But if any considerable amount of new equipment and different personnel are required for the production of non-radio lines, then it is the consensus that the manufacturer had better stick to radio. Some hold that the industry is getting down to just a handful of the strongest manufacturers, and that, with production competition reduced, it will be possible for survivors to smooth out the production and sales curves. The industry has been suffering from over-production and insufficient marketing information in the past, together with haphazard merchandising methods. These evils are being cleaned up. "The application of a little common sense to the law of supply and demand is what is needed," states one manufacturer, as the best solution of the production problem.

But what are radio manufacturers doing now regarding 1930-31 production? That is about the most difficult thing to find out—definitely. In a general way, we gather that full production will not be attained until October 15, which is several months later than in past years. Manufacturers are building up their production forces at this time. Parts manufacturers report receiving orders for larger amounts, although the orders are still very much like sample orders. Where large quantities have been contracted for, in order to secure low prices, the releases are just beginning to trickle through in an encouraging manner. Until the middle of August, most set manufacturers were doing nothing or next to nothing. Some were making a hundred receivers at a time, merely to keep their skeleton forces occupied and to keep their parts and materials purveyors lined up.

As of the middle of August, manufacturers reported anywhere from 30 to 70 per cent production activities, and expected to attain the 100 per cent or peak for this season by October. That peak, of course, is considerably less than last year, but then 1929 was an extraordinary year in radio as in many other lines. The peak is estimated at 75 per cent of last

year's production. One thing is certain: production schedules are based entirely on the marketing prospects. Manufacturers have learned their lesson. No longer are they plunging into enormous schedules without giving thought to what the market can absorb. Many manufacturers report a production schedule carefully balanced to actual demand. Controlled production is talked about on every hand. Some claim they were producing ten days ahead of actual orders, under controlled production.

Inventories

An important factor is that of inventories or unsold sets in the hands of manufacturers, jobbers and dealers. Various estimates of the number of unsold sets as of the middle of August, have been examined, and they apparently range from 200,000 to 500,000, despite the wildest kind of liquidation. We are told that of one brand alone, there are still 250,000 sets of last year's models, unsold. Sets have been practically given away in cleaning up last year's lavish over-production. It

PAUL KLUGH SAYS

Paul Klugh of Zenith Radio says: "Before the radio industry may expect to go to new peaks of production, prosperity must be nationwide."

now begins to appear that the public does not want the remaining sets at anything short of a gift. Desperate mark-downs mean less and less in moving those last remaining sets. The remaining sets are no grave factor so far as the new lines are concerned, for the public will want the new sets in preference to the old, irrespective of price considerations. The only drawback is that low price levels have been established for many leading brands of radio sets, and it is going to be hard work for merchandisers to educate the public back to the point of paying real money for new radio sets. That's the big trouble, as we see it. Some manufacturers feel that the remaining sets should be junked, if necessary, just so as to remove the barricade to this season's products.

The Radio Market

The radio market, aside from those old sets, is promising. The trade is reacting favorably to the new models. The controlled production idea is a big factor in restoring confidence all around. Also, there is a strong plea for better cooperation among manufacturers, to the end that they may produce at a profit, rather than glutting the market with goods that must sell at a loss. There is also a strong recommendation that manufacturers take steps to control distribution and merchandising outlets, so that their products may be properly merchandised

(Concluded on page 44)

A New Power Detector System

By Dr. Paul G. Weiller

Omitting the Grid Leak and Condenser, High Bias May Be Obtained By Inserting an Automatically Biasing Resistance in the Grid-Plate Return

History

THE first detector used in radio communication was probably the Marconi magnetic detector. It was abandoned very soon, when much more efficient methods were discovered.

The vacuum tube and the crystal appeared approximately at the same time. The crystal was used in preference to the tube, because good crystals were easily obtainable, while a considerable amount of work had to be done on the vacuum tube and its associated circuits before it could be used on an extensive scale.

Before the days of broadcasting, the soft detector tube, mostly similar to the well-known type 200, held the field. It was very sensitive, but was never required to handle considerable amounts of power. Its somewhat erratic behavior did not matter much during the period when radio receivers were handled only by experts.

With the advent of broadcasting, radio receivers rapidly entered the home of the average man. Therefore, requirements for easy operation and good tone became insistent. The well-known high vacuum grid leak condenser detector was a great improvement over the gas detector. It was very stable, quite sensitive and gave fair quality as long as small powers were employed. However, its sensitivity was not as great as that of the gas detector.

The demand for perfect reproduction brought the development of good audio transformers and output tubes handling large powers. Simultaneously,

radio-frequency circuits were improved to such an extent that appreciable voltages could be delivered to the detector, if the latter could be made to handle such signal levels, without too much distortion.

The tremendous increase in the power of broadcasting stations made this demand more insistent.

A number of articles, giving the theory and characteristics of the grid have been published and it would only be repetition to enlarge on this subject at this writing.

The Power Detector

While the grid leak detector is quite sensitive and can give fair reproduction for low input voltages, it will cause intolerable distortion, as soon as the input voltage reaches any considerable part of the admissible grid swing of the detector tube.

To obviate these difficulties, the so-called "power detector" was designed. The grid leak and condenser are omitted. A very high bias is obtained by inserting an automatically biasing resistance in this grid plate return.

At the same time, the plate voltage is raised from the 45 or 60, customary with the grid leak detector, to 180 or even 250 volts. We have, then, a tube biased nearly to the point of cut-off. The plate current is normally negligible, less than 1 milliamperere. If a signal is made to impinge on the grid of the tube, it is obvious that during the half cycle during which the signal voltage is added to the bias voltage, no appreciable decrease of the plate current can occur. On the sub-

sequent half cycle, however, the signal voltage will decrease the bias voltage. Therefore, an increase in plate current, proportional to the signal voltage, will occur; that is, this half of the signal wave will develop normally, while the previous half has been suppressed. Consequently, we will have in the plate current an exact reproduction of the subsequent positive half cycles of the signal voltage. This result is equivalent to rectification.

The power detector will permit the use of a relatively considerable voltage input to the grid of the detector. However, it still has some considerable disadvantages. Experience has shown that it lacks sensitivity at low signal levels. Because of the high grid bias, the plate impedance of a detector tube used in this way is very high. If transformers are used for coupling the detector to the subsequent audio amplifier, a very high impedance primary must be designed, if good quality is desired. This means a very large transformer, which is too expensive for the average receiver.

On the face of it, it may seem that resistance amplification following the detector would be the answer. It must be considered, however, that a power detector must necessarily use some 180 to 250 volts on the plate of the detector. It is obvious, therefore, that the high resistances necessary to make a good resistance amplifier cannot be used, as normal operation would then require voltages in excess of 500, which is undesirable for broadcast receivers, because of the filter economy necessitated by the moderate price at which they are sold.

New System Invented

The writer has endeavored to avoid these difficulties by a new detector system, which uses a combination of a vacuum tube and a non-linear resistance.

A metallic conductor will follow Ohm's law as long as its temperature is not raised; that is, the voltage drop in the resistor is exactly proportional to the current, the resistance remaining constant for all currents and voltages, as long as the temperature remains constant.

There are certain combinations of metallic and non-metallic substances, as, for instance, a combination of a steel point and a carborundum crystal, or a combination of magnesium metal and certain copper sulphides, which do not follow Ohm's law. Fig. 2 shows, on the right, the current-voltage curve of such a combination, where the volt-

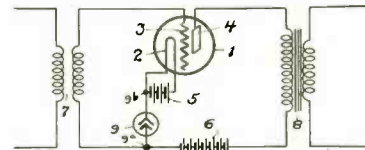

Fig. 1. Bias obtained by drop caused by plate current in non-linear resistance 9.

ages are the abscissae and the currents the ordinates in the diagram. Up to a voltage value e , the current increases essentially along a straight line. When the voltage increases above the value of e , the current increases only at a lesser rate, or, in other words, at that point the resistance of the junction increases. This is what is meant by non-linear resistance. This phenomenon is not necessarily the same as that employed in some types of crystal detectors, as the old-time galena and pyrites detector. Those detectors acted mostly as valves. They simply passed current only in one direction. Such a detector would not be suitable for the new power detector system.

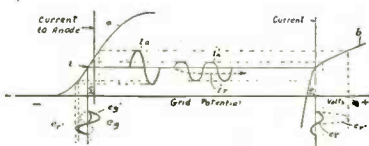

Fig. 2. Signal as reproduced in plate circuits.

Circuit Changes

In this new detector system, a non-linear resistance, as above described, is inserted in a standard power detector circuit, as shown in Fig. 1, at 9. It can be seen that this non-linear resistance takes the place of the customary bias resistance of the present power detector. As the non-linear resistance of Fig. 1 is located in the plate circuit, the grid bias is obtained by the drop caused by the plate current in the non-linear resistance 9.

The characteristics of this non-linear resistance must be chosen in such a fashion that when no signal is present, this system will be in equilibrium at a plate current equal to that at the point, i , of the voltage current curve of the non-linear resistance. Then, if the plate current increases, the bias voltage will increase at a rate equal to the slope of the curve from point i , towards b .

If the plate current decreases, the bias voltage will decrease towards a , at a rate corresponding to the slope of that part of the curve which is much higher. Therefore, if a signal impinges on the grid of the tube, and, remembering that the negative half cycle always adds to the grid bias what the positive cycle decreases the bias correspondingly, the signal will be reproduced in the plate current in the fashion plotted in the middle of Fig. 2.

If the wave e_1 below the zero line in Fig. 2. signifies the signal voltage, e_1^1 signifies the signal voltage superimposed on the bias voltage developed according to a non-linear resistance.

It can easily be seen that on one-half cycle the signal is practically nullified, while on the other half cycle it is slightly increased. Curve a , is a plot of the plate current grid voltage, characteristic of an average detector tube. i_a is the plate current curve corre-

sponding to the signal voltages, if the grid bias were constant. i_a^1 shows the plate current curve, if a non-linear resistance is employed.

The full half cycles in the plate current correspond to the full half cycles of the grid voltage (part below the zero line of the curve). The diminished half of the waves corresponds to the cancelled half cycles of the grid voltage.

It can plainly be seen that this system permits the use of high plate voltages, of an input signal voltage, of a maximum peak value equal to the full straight part of the tube characteristic.

There is little or no reason for the detector to cause any distortion. As the system works on a normal grid bias, for which the tube is designed, the plate impedance remains normal and an audio transformer of customary design may be used to advantage.

In summary, the advantages of this system consist in distortional rectification of large signal voltages, without requiring a redesign of standard amplifiers.

USING PICKUPS WITH POWER DETECTOR SETS

PRINCIPAL among the attractive features of the so-called "power detector" in radio receiving sets from the set manufacturers' point of view, is the elimination of one of the customary two audio-frequency amplifying stages. The commendability of this saving in tubes and in associated amplifying apparatus is immediately apparent but it is not without certain shortcomings.

The perfection of the electric phonograph pickup by means of which recorded entertainment is amplified in the radio set and reproduced through the loudspeaker has resulted in an inseparable union between the phonograph and radio. In sets of an earlier vintage, the two stages of audio-frequency amplifications incorporated in them were employed to amplify music picked up from the phonograph disc and it so happened that the magnifying power of this part of the receiver was of the proper order to do the job effectively.

Now that the power detector has made its appearance in the radio set generally with the elimination of one stage of audio-frequency amplification, the electric phonograph pickup can no longer be connected to the receiver in the ordinary manner if satisfactory results are desired. Sometimes volume from the single audio stage will be barely audible. Of course, various schemes have been suggested as a means toward eliminating this obstacle, among which were suggestions for connecting the pickup ahead of the detector tube. The effect with this arrangement, however, is not altogether unquestioned efficiency, so that Patent Electric Company engineers set about to design a unit for that purpose.

The Booster

After considerable experimentation and the rejection of more than a dozen impractical schemes, a unit known as the electric pickup booster was developed. Essentially, the booster—when connected to the receiver through a simple plug-in adapter—provides an additional stage of audio-frequency amplification for reproduction of phonograph records. It can be placed on top of the receiver console.

Two phone-tip jacks are provided at one side of the booster to accommodate the leads from the electric pickup. The cable connecting the unit to the receiver terminates in a special five-prong adapter which plugs into the detector tube socket in the radio set. The detector tube, previously removed from the set, is then plugged into the top of the adapter and a 227 type of tube inserted in the booster itself.

Operation

The operation of the unit is of greatest simplicity. A double-throw switch located just to the left of the phone-tip jacks indicates "radio" and "record" positions. When thrown toward the "radio" position, the detector tube in the receiver lights and broadcast entertainment may be received. When the switch is thrown to the "record" position, the detector tube is turned off and the tube in the booster unit lighted and, after permitting sufficient time to elapse for this tube to "heat up" music picked up from the record may be reproduced. An extra brown wire coming from the cable sheath, with a spade clip terminal at its end is connected to the ground binding post.

When the booster is used with Radiola 60 and 66 Models, the link connecting the two binding posts just to the left of the phono-record switch must be removed. With all other models of receivers, the link should be permitted to remain in place. In certain sets, such as a few of the Philco models, having 227 type first audio tubes, it may be found that the booster will operate better when the adapter is plugged into the first audio tube socket instead of into the detector.

After the booster was developed and perfected, it was found that it was possible, in many cases, to gain a considerable increase in amplification, by using it with sets having two stages of amplification, thus providing a three-stage amplifier. Yet, no matter in which position it is employed—detector or first audio—the power pack in the receiver cannot become overloaded since the detector or first audio tube, as the case may be, is turned off when the booster is in operation.

A very decided advantage of using the booster is that the impedance of the transformer primary incorporated in it is designed specifically for the electric pickup and because of this highly desirable operating condition, reproduction on the whole will be far superior to instances where impedance matching is not nearly so accurate.

Mixing Circuits and Transformers

The Relative Efficiency
and Calibration of Vol-
ume Controls Is Ex-
plained in Understand-
able Terms

By E. W. D'ARCY*

Relation of Volume Control to Speech Input Apparatus Is Here Described

IN the author's previous articles, a detailed analysis of the correct type of volume control to use with different types of speech equipment was presented. With the purpose in mind of clarifying the detailed application of these principles to speech input apparatus as well as methods of testing the relative efficiency of different volume controls and the calibration of them, the author presents this article.

Method Used in Attenuation Calibration

One of the most needed requisites of any volume control is that the attenuation must be designed to allow a well distributed control over the largest percentage of contact movement. To further illustrate this fact a curve of a constant impedance volume control is presented in Fig. 45. This particular curve has been made under the assumption of the pad network operating as a power device and not a potential device. As has been pointed out previously, this classification must be established before any intelligent idea of the required volume control may be obtained.

The requirements for workable attenuation are obtained by deciding the minimum audible signal in the system requiring volume variation. A curve of power levels with reference to a zero level of .006 watt is given in Fig. 46. Easy determination of volume control requirements may be obtained by consulting this data.

To be more explicit, citing the attenuation curve shown in Fig. 45, we can determine that the power output of a device when used with the volume control mentioned can be varied smoothly between .006 watt and 19 watts. This reference must not be construed to mean that power levels of the order of 15 watts can be handled by the volume control whose attenuation curve is shown but rather it should be taken to mean that when one of these controls is used on the input to an amplifier system capable of delivering this power to a load such as furnished by a speaker bank or amplifier input, linear volume variation

can be obtained between the two levels previously mentioned.

Further understanding of volume control requirements for mixer circuits can be obtained by consideration of the power output of the average radio set which varies between a minimum audible output of 50 milliwatts and a maximum power output of 5 watts. From this average data it can be determined that the over-all volume variation for good reception varies between these limits. By comparison of these figures with the data sheet in Fig. 46, it becomes apparent that volume variation allowable for successful reproduction in an un-monitored receiver should be held between these limits, which amounts to 19 decibels.

Variation in volume of an average orchestral selection exceeds 60 decibels and as the average radio will not reproduce this volume variation it can be seen that some compromise has to be effected between the limits set by

the radio sets used at the present time and the volume variation required for distortionless perspective in broadcasting.

The one redeeming feature about being unable to duplicate the volume perspective of an orchestra is the fact that the average radio listener does not desire orchestral volume in his living room. Since some compromise has to be effected, due to the conditions mentioned, the volume variation is held by the broadcasting station to not exceed 40 decibels.

The fact that a radio station is not paid for the part of the program not heard due to atmospherics, or other causes, when the program level is set for the best volume perspective, is also quite apparent. Since this is the case the level of any talent, whether it be orchestra, adult, or a child, is transmitted at the same volume level. As a rule the transmitter level is set at almost the extreme limit of modulation for the entire program, the high spots being attenuated and the low level parts being raised in level to obtain the desired effect.

Due to the above mentioned conditions a mixer control should be so designed with respect to attenuation versus contact travel that at least 30 decibels of attenuation should be linear with 80 per cent of the contact travel. This construction allows a very smoothly controlled output when operated in conjunction with a master gain control having steps of 3 decibels.

Attenuation Calibration

A schematic diagram is shown in Fig. 47 of a test setup used in the development of volume controls. Commercial power is used to supply the energy for testing. A potentiometer which has been accurately calibrated is connected across the input to the pad under test and by means of a switching arrangement a vacuum tube voltmeter is connected either to the potentiometer arm or across the output of the attenuation network. The readings are then balanced by means of the adjustable potentiometer arm and when this condition has been fulfilled the attenuation shown by the calibrated potentiometer is equal to the network attenuation.

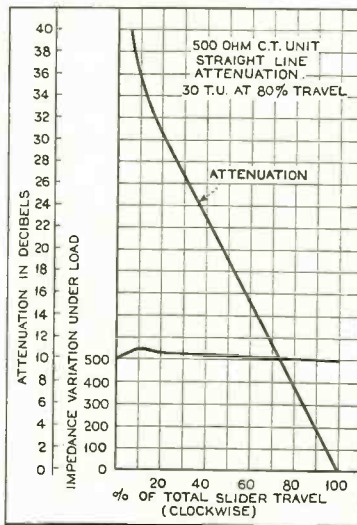

Fig. 45. Constant impedance volume control.

* Chief Engineer, D'Arcy Laboratories.

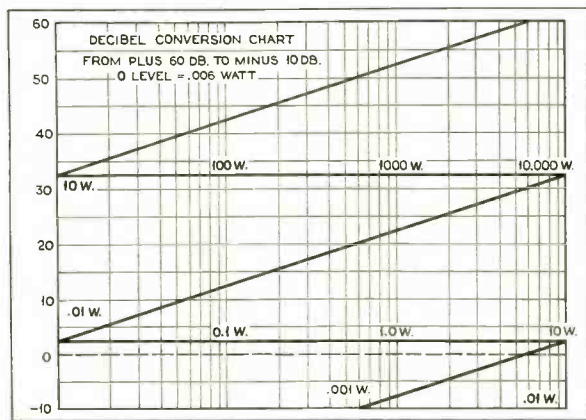

Fig. 46. Graph of volume limitation.

In the case of pad networks a terminating load should be supplied by means of a resistor, if it is being used as a power device. When used in measuring, a voltage divider type of volume control, no load, is required.

For checking impedance constancy of the volume control a Wheatstone bridge is connected to one side of the network and the other side is terminated in the resistance load for which it is designed. A diagram showing the test setup is given in Fig. 48.

Speech Input Transformers

Before an intelligent idea of the proper characteristics of a speech input transformer can be determined, an analysis of the generator and load impedance in conjunction with which it is used, must be made; that is, whether its characteristics are inductive, resistive or capacitive, and their power factor and phase angles determined.

The condition of maximum power transference occurs when the phase angle between the generator and load is conjugate. Some compromise has to be effected in this respect, but it is well to bear this fact in mind in the design of transformers. Also, the transformer should introduce no appreciable load in the circuit, its function being merely to transfer power at different potentials or match the impedance of the generator with the load. Therefore, it is fairly obvious that the reactance of any winding of a transformer should be several times the impedance of the generator or load with which it is being used.

In the case of carbon microphones or vacuum tubes, where the impedance characteristics are resistive and not inductive the transformer should be designed to furnish an efficient transfer of energy at the lowest frequency it is to reproduce. As an illustration, the average carbon microphone has an a-c. resistance of 100 ohms to the button, consequently transformers designed to be used therewith have a self inductance of high enough value to insure efficient transfer of energy down to the lowest cut-off frequency. As a typical case, one

well known manufacturer's transformer used for microphones has an inductance of 1 henry per button. The reactance of an inductance of this value at 60 cycles would be 377 ohms, which is 3.77 times the effective a-c. resistance of a single button. As the frequency is decreased, the transformer becomes less efficient and we find that at 16 cycles, corresponding to the lowest pedal note of an

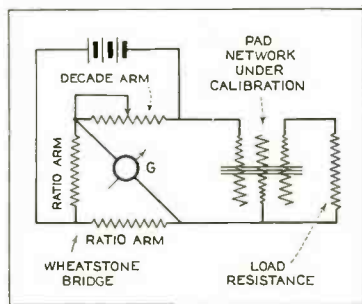

Fig. 48. Impedance constancy test.

organ, the reactance of an unloaded primary of an inductance of the value mentioned would be 100.05 ohms. At this frequency, therefore, since the a-c. resistance of the microphone does not change with frequency, the transformer absorbs power instead of transferring it to its load at a minimum of loss.

Transformer design practice indi-

icates that to obtain an impedance match between unlike impedances the turns ratio of the transformer should be equal to the square root of the impedance ratio. As an illustration, a transformer designed to match a carbon microphone to a 50-ohm load would have a turns ratio of two to one.

The same conditions as stated about a carbon microphone are also applicable to vacuum tubes, although practice has indicated that a tube will deliver its maximum undistorted output when operated into an impedance of twice its own internal output impedance. A good interstage or output transformer, therefore, should have its primary inductance of a high enough reactance so as to place no appreciable load upon the tube except by the reflected terminating load at the lowest frequency determined as the cut-off point.

Requirements of transformers operating in an audio circuit from an inductive generator are somewhat different. Here, instead of an impedance independent of frequency, we have an inductive reactance and its output impedance, of course, varies proportionately with frequency.

It is good practice, therefore, for manufacturers of electromagnetic reproducers, or other inductive devices, to state the impedance of their products at a standard frequency which in most cases would be 1000 cycles. It is readily understandable now that if the transformers are designed to afford efficient transference of energy at 1000 cycles, the same values of inductance will be efficient at the other audio frequencies within the limits mentioned.

Some difficulty enters in connection with controlling the volume in inductive devices. This is due to the fact that when a simple variable resistor system is used, it does not alter its a-c. resistance with frequency, and unless its value is kept high enough to insure good response to the highs at all values of attenuation considerable loss of the higher register will be evidenced.

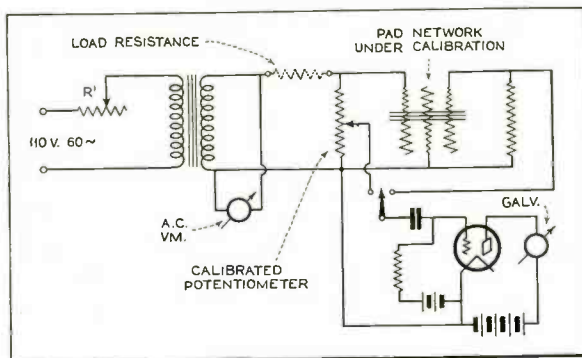

Fig. 47. Test setup for volume controls.

It is easily seen from the foregoing that volume controls have considerable to do with the performance obtained from any speech circuit, and it is also quite obvious that a good transformer when not used with proper equipment will give mediocre results.

It is also noticeable that considerably more difficulty is encountered in obtaining good performance from any device whose impedance changes with frequency than from a device such as a carbon microphone or vacuum tube where the same condition does not ensue.

Telephone lines as leased by the telephone companies are so equalized and balanced as to present an impedance which remains constant with variation in frequency. Therefore, transformers designed to be used in conjunction with the input furnished by them can be designed on the same assumption as previously discussed regarding carbon microphones or vacuum tubes.

Mixer Circuits

Numerous inquiries have been received by the author regarding the use of pad networks in mixer systems, and in response to this interest the author is presenting a mixer circuit which has proved to be of practical value in public address, motion picture equipment, and broadcasting stations.

M. K. 57 Specifications

Circuit M. K. 57, Fig. 49, is the most logical system of mixer circuit and is being used universally at the present time in motion picture studios and broadcasting stations.

By reason of the series connection of channels, various losses are eliminated. The load impedance placed across any individual channel by other channels is practically infinite due to the fact that the input transformer may be considered as a purely potential load and all other channels are operating in series with this potential load.

Arrangements can be made to allow as easy a change of mixer channels between amplifiers as the parallel system with very little further complication of circuit arrangement. The specification number is M. K. 72.

The output of the bank of series mixers can also be connected into another bank of mixers through one of the 200-ohm channels of the second bank. This allows multiplication of mixer facilities while still insuring good impedance balance.

The mixer volume controls function admirably when used in a series mixer circuit as shown in Fig. 49, and any one of the channels can be raised in

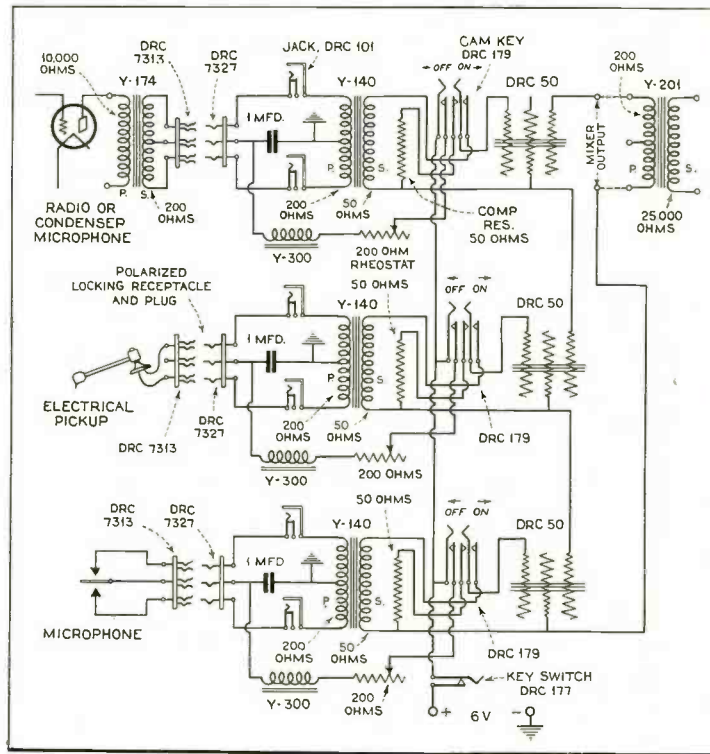

Fig. 49. Mixer circuit wiring widely used in sound studios and broadcasting stations.

level from minimum to maximum without affecting the signal level or quality of the other operating channels.

In permanent installation the complete mixer bank can be operated through an additional resistive network to reduce the program level to an appropriate background for special effect announcements and features. This can be accomplished by proper relay and key arrangement.

Anti-Cross Talk Precautions

The condensers and chokes inserted in the microphone battery leads are also quite necessary, as complete avoidance of picking up the make or break of any individual microphone circuit by other operating circuits is assured as well as elimination of any tendency to cause cross talk between circuit channels.

Locking Type Receptacles

In most types of modern portable speech input equipment locking type receptacles are standard and while it seems ridiculous to use a receptacle and plug arrangement designed to handle commercial amounts of current for such a purpose, yet the avoidance of noise secured by using receptacles and plugs of ample proportion is really of much importance as only too often a program is completely marred by a so-called performer clumsily trip-

ping over the microphone cord and either causing an unmusical clatter to be broadcast, or completely ruining the program by pulling the microphone out of its receptacle.

Hoping that the foregoing suggestions will be of assistance to readers interested in the construction of such equipment, the author brings this discussion on basic mixer circuits to a close.

R. C. A. COMMUNICATIONS APPLIES FOR USE OF HIGH FREQUENCIES

THE present radio outpost is in the region of 23,000 kilocycles. R. C. A. Communications, Inc., the radio communication branch of the corporation, desires to experiment in the territory ranging up to 400,000 kilocycles. Commercial code and telephone communication now are carried on at a maximum of 23,000 kilocycles; beyond this, engineers explain, the "skip-distance" effects of emitted signals have baffled science.

The application filed by R. C. A. is for a license to allow it to operate experimentally on twelve channels in the high frequency spectrum with but fifteen watts power, with a portable station in the vicinity of Riverhead, N.Y. The small amount of power requested, it is pointed out, is occasioned by the fact that the higher the frequency the less power is needed to cover broad expanses of territory.

Engineering the Battery Radio Set

By W. H. HOFFMAN and DON R. MIX*

There Is a Big and Waiting Market for Battery Radio Sets, But Engineers Must Do Their Job Before Merchandisers Can Do Theirs

THAT there is a large and waiting market for the battery-operated broadcast receiver, goes without saying. However, until now the so-called farm or rural market has failed to come up to expectations, so far as radio merchandisers are concerned. The reason is simple enough: engineers, asked to concentrate on the a-c. receiver, have not, as a group, given sufficient thought to the requirements of the rural or unwired home, and merchandisers have not been given much encouragement.

What are the radio requirements of the rural or unwired home? First, the ability to tune in relatively distant stations, since there are greater distances to span than in the case of the urban home. Second, a fair degree of selectivity, although perhaps not so much as that required by the urban home. Third, sufficient volume so that the radio rendition may be enjoyed by a group of listeners, although by no means auditorium volume, which is quite unnecessary in the average home. Fourth, good tone quality, for everyone knows today that radio rendition may be highly realistic. Fifth, and of prime importance, low operating cost, since socket-power operation has established an entirely new standard of cost for radio entertainment. And as part of the same requirement, the freedom

* Engineering Department, Burgess Battery Company.

from frequent recharging of the storage battery, and from frequent replacement of the B dry batteries used.

Just how many homes are in need of a satisfactory and economical battery-operated radio receiver, is a matter for speculation. However, statistics tell us that there are 9,250,000 unwired homes in the United States, as contrasted with some 17,000,000 wired homes. In other words, for every two wired homes, there is an unwired home. The market for a satisfactory and economical battery receiver is just half that of the socket-power radio set, but, most important, it is a relatively unexploited market. We are told by the Department of Commerce that many unwired and rural homes are still using primitive crystal receivers. Of the total of 9,250,000 unwired homes, obviously some allowance must be made for the poorer homes which cannot afford any type of radio set. However, such homes are in the minority, so that a market of 6,000,000 unwired homes at least is awaiting the satisfactory and economical battery set.

There is nothing new about battery-operated sets. Indeed, they came immediately after the crystal sets, and were followed by the electric or socket-power receivers only three years ago. Yet engineering attention has been concentrated on the electric or socket-power receiver during the past three years, while little has been done

on the battery type. Only a few set manufacturers produce battery sets, which have a limited sale because in some particulars they do not bear comparison with electric sets of the same vintage.

Unwired Homes

Present battery sets do not meet the unwired home requirements. They fail in volume, tone, uniformity of results, and operating cost. The poor and varying tone quality may be traced to the manner in which the biasing potentials for the grids of the various tubes in the receiver are obtained. The biasing potentials are universally obtained by means of a separate dry battery generally designated as the C battery. It is well known that the correct value of these potentials is fairly critical if distortion is to be avoided. With a given type of tube, this correct value of biasing potential depends upon the value of plate potential used, in a battery-operated receiver. This plate voltage gradually falls as the voltage of the B battery decreases with use. However, since there is no drain upon the C battery, its potential remains practically constant. As the B battery voltage drops, the plate potential soon assumes a value to which the unchanging grid potential is wholly unsuited, resulting in an abrupt drop in plate current and accompanying distortion and loss of sensitivity.

A New Receiver

In order to put our findings and deductions to critical test, we designed a battery-operated chassis known as the Burgess receiver No. 18. To avoid the unbalanced B and C potentials found in the usual battery operated receiver, we developed a different method of securing automatically corrected grid biases at all times. The system incorporated, while not new in the a-c. receiver field, is an innovation in receivers, of the battery-operated category, and in this class has a distinct advantage not apparent when used in the a-c. type receiver. In this receiver, the grid potential for each type of tube is secured from the voltage drop across a resistance of proper value placed in the B battery lead. Since the grid potential now depends upon the drop across the resistance which varies with the value of plate current through the resistance which, in turn, depends largely upon the value of plate voltage, it is clearly seen that as the plate B battery voltage falls off with use, the value of grid potential also falls off. This method of biasing also has the advantage of eliminating all necessity for C batteries. Of almost equal importance, from the merchandising standpoint, is the fact that by eliminating C batteries, the set is made much simpler. There is no elaborate cable with almost a dozen connections, but instead a simple cable with just a pair of A and B battery leads. There are no formidable C battery wiring instructions to frighten the

prospect. The chassis is relatively clean, impressive, attractive.

Since there is an appreciable drop in voltage through the biasing resistances, the total plate voltage available for the plates of the tubes is reduced. To compensate for this loss, an additional 45-volt block of B battery is used, making a total of 180 volts for the 135-volt tubes. While this apparently adds to the battery cost, it will be remembered that no C batteries are required, so that the initial battery cost remains practically unchanged.

The second cause of trouble in using the B batteries to a low end voltage, is much less serious, according to engineers. This is the trouble caused from oscillations in either audio or radio-frequency amplifiers due to coupling introduced between stages caused sometimes by increased resistance of the B batteries as their age increases. This cause, we believe, is much less frequent than is normally suspected, as it has been found that any well-designed amplifier is free from troubles from this source. Carefully designed filters will eliminate any possibility of coupling through the batteries, and since such filters are prerequisites in modern amplifiers of high gain, no trouble from this source should be experienced.

Comparative Tests

To determine the limit of B battery end voltage, a test was made on receiver No. 18 as well as on three commercial battery sets. These tests were run continuously 24 hours per day without interruption and readings were made approximately every 24 hours. In each case a set of four Burgess No. 21308 "Super" B batteries was employed. Only 300 to 550 hours of service was obtained on the commercial sets without encountering serious loss of quality or volume. The B battery end voltages averaged about 37 volts per 45-volt unit. On the other hand, the Burgess receiver No. 18 maintained its quality and a satisfactory proportion of its original volume for a period of 950 hours of continuous service, at which time the B battery end voltage was 22 volts per 45-volt block. At 950 hours the maxi-

Fig. 1. Tube performance where older types of dry cells are used.

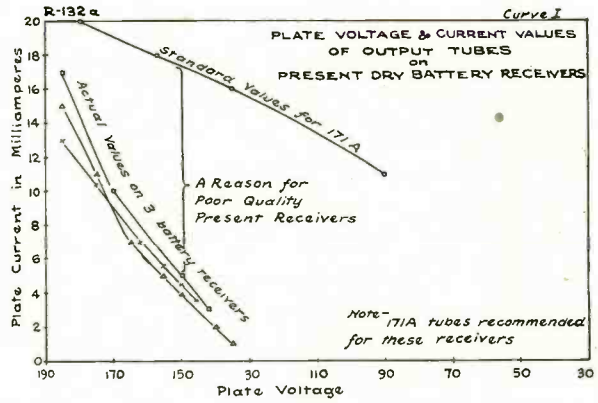
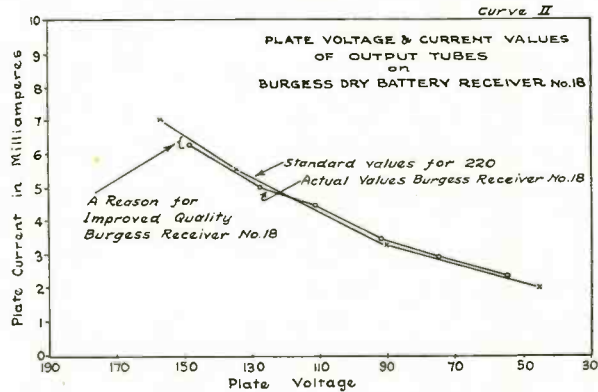

Fig. 2. Tube performance with modern dry cells.



mum volume had fallen to a point which might be considered too low for satisfactory reception.

To determine if the discharge of the B batteries might be carried further without trouble, two new 45-volt blocks were added in series to those already in use and the discharge continued for an additional 240 hours. This gave a total of nearly 1200 hours of continuous service. At this point the batteries each showed a closed circuit voltage of 10 volts per 45-volt unit.

A total of 16,000 milliampere-hours had been taken from the original set on continuous service.

An increase of at least 50 per cent in this service may be expected with ordinary intermittent use. During the entire test, no trouble was experienced

at any time from noises or instability of amplifiers. At the conclusion of this test the B batteries were broken apart. Inspection showed that while the zinc cans were well perforated, no leakage had occurred between cells due to the excellent individual insulation between cells, which accounted for the lack of open circuits or leakage current between cells.

A Battery Drain

A second important item which should be considered from the viewpoint of economy and convenience is the matter of A battery drain. This is limited mainly to the selection of available standard tubes. Until recently, this has been quite a problem to the engineer due to the lack of satisfactory tubes of low filament current consumption. The general difficulties encountered with available low-current tubes has been the lack of amplification as compared with heavier current tubes, comparative low value of undistorted output of tubes of the power class, severe tube noises caused by weakly supported elements and the ease with which the tubes were "paralyzed." The lack of satisfactory tubes has, no doubt, been due largely to the focusing of engineering attention on the a-c. operated tubes.

During the early part of this year, however, several manufacturers have once more turned to the improvement

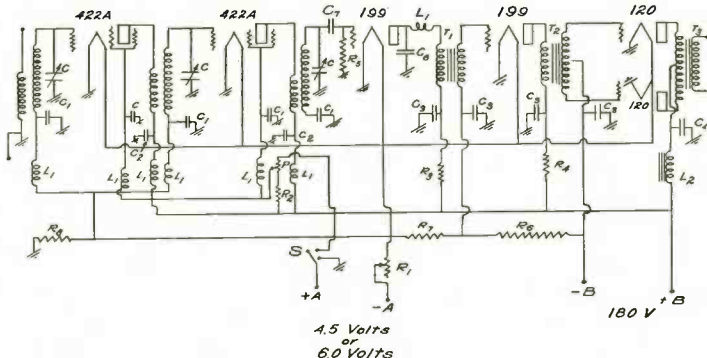

Fig. 3. Theoretical hook-up of dry-cell operated receiver.

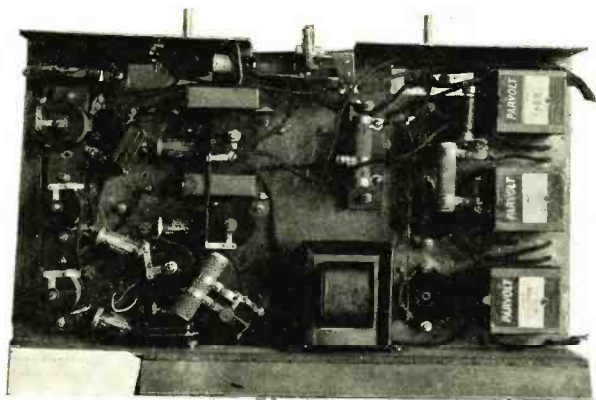

Fig. 4. Placement of elements of receivers.

of low-current tubes for battery operation. The first important step was the development by DeForest of a screen-grid radio-frequency amplifier of increased amplification and a filament consumption of one-half that of the original -22 type. During the first tests of receiver No. 18, two of these tubes were used followed by a standard -99 tube as detector and another -99 for the first audio stage, and two standard -20 power output tubes arranged in push-pull. This provided a six-tube combination which, operating at the rated filament voltage of 3.3, drew less than one-half ampere. The economy in filament power can easily be appreciated when it is considered that each of the three standard sets drew a total of from $1\frac{1}{4}$ to $2\frac{1}{2}$ amperes from the A battery. On continuous test it was found that while other receivers obtained 36 to 70 hours service per charge from a 100 ampere-hour storage battery, it was possible to secure 150 hours of service from the same A battery with the new receiver. This not only means an appreciable economy over the other sets but, much more important, is the fact that it reduces the necessity of inconvenient recharging of the storage batteries. This is an important factor where the rural user is to be considered.

A New Line of Tubes

Still more recent is the development of a new line of battery tubes to operate at 2 volts filament potential. Each type draws but 0.06 ampere, except the power output tube which draws 0.15 ampere. This makes possible a six-tube arrangement similar to that previously described, drawing a total A current of less than $\frac{1}{2}$ ampere, with the added advantage of calling for only a single 2-volt storage cell, reducing materially the size, weight and cost of the A battery. Other marked improvements incorporated in this line of tubes are an increase in amplification factor of the general purpose tube which puts it in the -01-A class; an increase in the amplification factor of the screen-grid tube which makes it practically equal to the present a-c. tube of this type:

and an appreciable increase in the undistorted output of the power tube. Another important improvement is that all of the tubes are rigidly made, eliminating practically all objections to the "microphonic" noises so prevalent in the earlier types. All types include the oxide-coated filament, considerably reducing the hazard of paralysis.

As soon as these tubes were available, an installation was made in receiver No. 18 for test. To furnish additional data, this second test was run using four No. 2308 45-volt blocks of B battery. This type of battery is of much lower rated capacity than those used in the previous test and represents a battery of the lower price class. In using these tubes, all rheostats and other filament circuit resistances were removed and the tubes operated on direct connection to a single two-volt storage cell without adjustment. Most satisfactory operation has been secured in this manner and actual tests show that at the rated voltage of 2 volts, the total current drain of a set of the six proper tubes is well under one-half ampere. These tubes will operate without noticeable fluctuation in sensitivity or volume over the usual voltage range of a storage cell, namely, 2.1 to 1.8 volts.

The B Drain

As for the B drain when using the new 2-volt tubes, it remains substantially the same in character as when using the 3.3-volt tubes. However, it is possible to use the batteries to a still lower end voltage without excessive loss in quality or volume in the 2-volt tubes. This is due principally to the increase in sensitivity of the 2-volt screen-grid tube over its predecessors. While the usual capacity rating of the No. 2308 battery is only about one-third that of the No. 21308 super battery used in the first test, satisfactory performance was secured over a period of 504 hours of continuous service with the Burgess battery No. 18. Allowing 50 per cent increase in service for intermittent operation, six months was considered as the average period of usefulness, provided by this smaller type of battery. It

might also be mentioned that the initial B battery drain was 28 milliamperes in the first test when 3.3-volt tubes were used.

While several manufacturers of dry battery sets have turned to the use of the dynamic type speaker, this adds materially not only to the maintenance cost due to the additional battery drain, but also to the initial cost of the receiver equipment. The results obtained by one manufacturer in the development of the magnetic type speaker show that there is still room for considerable improvement in other speakers of this type. In the Model 18 receiver, the Farrand inductor dynamic, or modified magnetic type speaker, has been employed. This loudspeaker has tonal qualities equal to most dynamic speakers and will handle a surprising amount of power without overload.

Small Number of Wires

Another point which has become a considerable source of trouble and irritation not only to the purchaser of a battery set but also to the dealer and serviceman is the ever-increasing and changing number of battery leads without a semblance of standardization, a misplacement of one or more of which is easily made and renders the set inoperative temporarily, if not causing actual damage to the receiver itself. In the design of receiver No. 18, this fault has also been kept in mind. It has been previously described how the necessity for all C batteries is eliminated. In addition to this, fixed resistances of proper value have been used to secure the proper plate voltages for the detector and first audio tubes, and also for the shield-grounds, rather than the use of taps on the B battery. By these means, the battery leads have been reduced to a total of four, *i. e.*, a pair for the A battery, and a pair for the B battery. The resistances also form a part of the filter system. It also has the advantage of placing an equal load on the entire B battery, and, in the case of well-made batteries, the lives of all units are practically the same and all are ready for discard at the same time, removing the necessity of frequent testing. This idea also includes the possibility of the efficient use of a single 180-volt B battery, without taps, which may make a good merchandising point.

The circuit diagram, Fig. 1, shows all the important circuit constants. These constants are those used with the 3.3-volt tubes. Slight changes in the biasing resistors and the elimination of the filament rheostat are the only necessary changes to adapt this set to the use of the new 2-volt tubes. A change in method of volume control to the antenna circuit may be found more desirable since, in the position shown, biasing potentials on the tube grids are slightly affected by the setting of the volume control.

(Concluded on page 44)

New All-Purpose Testing Instrument in Factory and Laboratory Saves Money

THE radio production engineer is constantly on the alert to turn out a better product, and to do this consistently at the lowest possible cost. Naturally, he utilizes ultra-modern design, labor-saving machinery wherever possible, and highly skilled workmen where needed. He selects his raw materials with the utmost care, so that the finished product will have long life as well as high operating efficiency.

Through the efforts of radio engineering organizations of experienced specialists, concentrating exclusively on the development of testing equipment, comprehensive lines of precision instruments are now at the service of progressive production engineers.

Useful in Research

These new instruments are useful in radio research work, in the electrical testing of raw materials, in testing during the process of assembling and wiring and in the testing and checking of finished products. Where trouble is encountered, certain of these devices locate faults with marvelous rapidity and accuracy.

In the laboratory of the radio set manufacturer, one type of instrument stands out pre-eminently as the ideal all-around testing and checking device.

An ideal instrument is one which is universal in its application, making every conceivable test on any type of radio set. A preferred type is one which is simple to operate and which can be put to immediate use without loss of time in studying intricate directions. It is positive in action and accurate in results. It is self-contained and does not require auxiliary meters, batteries, etc. It cannot be injured by careless, unskilled handling. In short, it produces the desired results simply, accurately and efficiently in a manner certain to delight the most discriminating radio engineer.

Here are a few of the tests possible with an all-purpose instrument of this type. It tests all types of tubes, including screen-grid tubes, pentodes,

Radio Production Speeded Up and Made Efficient

By H. G. CISIN, M.E.



over-head heater types, new 2-volt tubes, etc. The oscillation test employed gives the only easily-made, dependable tube test, under radio-frequency operating conditions. It affords a mutual conductance test of tubes and in the case of the 80-type full-wave rectifier tubes, permits a test of both plates.

The instrument locates unbalanced power transformer secondaries; reads either positive or negative cathode bias; furnishes a modulated signal for testing, synchronizing and neutralizing; and provides means for aligning condensers either by thermocouple or by an a-c. meter. With the assembly, it is possible to perform neutralization with tubes used in the set. This is the only accurate method and is the ideal procedure where tubes are supplied with the receiver.

Many Tests Practicable

The advantages of all-around testing instruments are readily apparent. Such an instrument will test the gain of audio transformers, provide d-c. continuity tests without batteries and bridge open stages of audio for testing.

Without the use of batteries it can be used for indicating resistances in four ranges, namely, 1 to 25 ohms; 10 to 200 ohms; 150 to 30,000 ohms; 5000 ohms to 5 megohms. It will also measure the capacity of condensers from .1 mf. to 9 mfs.

Instruments of this type provide a high resistance continuity test for checking voltage dividers, insulation leakages, by-pass and filter condenser leakages, bias resistors, grid leaks, etc. They provide low resistance continuity tests for checking rosin joints, shorted variable condensers, center-tapped filament resistors and many other low resistances. In testing for shorted variable condensers with this

The Day of Haphazard Tests and Hoping That Receivers Will Work Has Gone By

instrument, it is unnecessary to disconnect the r-f. coils.

In spite of the fact that such instruments have provisions for making every test required in the manufacturing of the modern radio set, the instrument itself is remarkably compact and simple in construction. More important still, it is easy to operate, even where the particular test is being made for the first time. With one make a loose-leaf manual is provided with each instrument. This manual gives explicit directions for using the instrument to the best advantage. The instructions can be understood and followed by anyone who can read, and to avoid the possibility of ambiguity, the written directions are supplemented by pictures which tell the story of each test at a glance. In addition to the instructions, the manual contains a veritable storehouse of information useful to the radio engineer and as new tubes and other radio devices are produced, new data sheets are issued for insertion in the manual.

The instrument contains its own power plant. Within the instrument is a step-down transformer, so that the ordinary house-lighting alternating-current may be used to provide the different voltages required for testing various types of tubes. The tapped secondary furnishes 1.5, 2.5, 3.3, 5.0, 7, and 15 volts and there is a selective switching arrangement for connecting any one of these voltages to the filament circuits of the tube testing sockets as desired. By the use of selector switches, the plate and oscillating circuits are automatically closed, at the same time disconnecting the power plant from other parts of the instrument. Through the use of a master plunger in the 110-volt a-c. line jack, it is possible to take readings of the line voltage being supplied to the power plant primary at any time during the tests, thus permitting corrections for variations in line voltage.

The test instrument is equipped with three precision meters, consisting of a four-scale d-c. voltmeter, a four-scale a-c. voltmeter and a three-scale milliammeter. It also contains a 500-000 ohm variable resistor, a 30-ohm

rheostat, and .001 mf., .002 mf. and 1 mf. condensers for testing. External connections are available to all apparatus.

Voltage Determinations

The device also contains a universal analyzer plug and provides simultaneous plate current and plate voltage readings and the customary readings of a-c. and d-c. filament voltages, grid voltage, cathode bias, screen-grid voltage, line voltage, etc.

An important point about the instrument is that it is readily portable, so that it can be moved from the laboratory to the workbench or to any other part of the factory, or can be used on outside jobs with equal facility. Portability is attained through the use of a well-constructed carrying case, 7½ inches by 12 inches by 16½ inches, providing extra space for tools, spare tubes, and other parts. A smaller case, 7½ inches by 8 inches by 18 inches, is also available where spare tubes and tools are not required in the same unit.

When the instrument is returned to the laboratory, it is generally mounted in a test panel, designed especially to hold it. The instrument tray is removed from the carrying case and inserted on the back of the panel, being held there by substantial brackets. In this position, the top of the tray faces through the opening in the panel, thus forming a part of the panel itself.

Below the space occupied by the panel of the instrument tray, there are twenty-three pin jacks corresponding to the twenty-three pin jacks on

Testing instrument for radio manufacturing and servicing purposes.

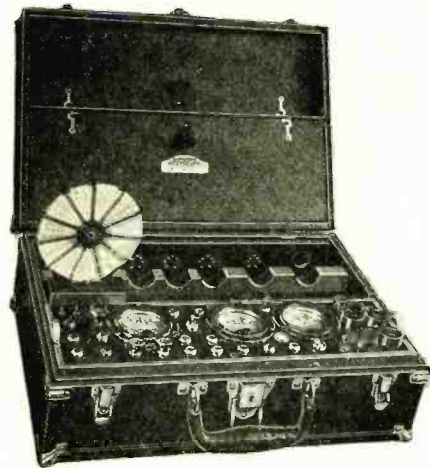

the rear of the instrument tray. Flexible leads are soldered at the rear of the panel to each pin-jack. These leads are then brought into a cable and terminate in pins which pass through a bakelite connection block in which the pins are so spaced as to accurately fit on the back of the instrument tray. As a result, the instrument tray can be made an integral part of the test panel in a few seconds and it can be removed just as readily, placed in its carrying case and converted into a portable laboratory. The utilization of a special variable condenser on the panel, provides a means of controlling the frequency of the oscillator contained in the instrument.

Hence, the oscillator can be tuned to any frequency desired, within the broadcast band.

The radio set manufacturer should investigate most carefully the possibilities of universal testing instruments. Manufacturers of loudspeakers, of radio accessories and of parts used in radio sets, will find the instrument a handy aid, not only for research laboratories, but also for testing and checking at various stages in the manufacture of products.

One instrument of the type and usefulness described herein is the *Diagnometer*, manufactured by the *Supreme Instruments Corp.*, of *Greenwood, Miss.*



PRACTICAL LABORATORY OSCILLATORS

(Concluded from page 30)

means of the filament-clip, proper adjustment is possible.

There are many tests which can be performed with the simple oscillator of Fig. 9. It requires a minimum of apparatus and will be popular with many servicemen for general testing. All connections are made to clips on the baseboard. Two of these oscillators will furnish a beat-frequency oscillator. Condensers can be compared by connecting them in parallel and returning to zero beat. Many other tests can be performed with an oscillator of this inexpensive type.

It is often difficult to arrange a coupling coil so that proper coupling values can be selected and found again, when once determined. This applies especially to transmitters. There are many possible arrangements; but flexible leads, for this type of work, cannot ordinarily be employed. A convenient coupling arrangement is shown in Fig. 10. This set was designed by the author for the Borden Field Arctic

Expedition, KGEG. The antenna panel in this set fits into a groove at the front of the baseboard. A small baseboard, which slides on the main baseboard, is screwed to the antenna panel. The brass guide shown, holds the small baseboard in place whether the set is right side up or upside down. The arrangement shown, proved to be very flexible in practice and can be used also in the laboratory. This transmitter was mounted on the ceiling of the radio room and therefore appears as if inverted.

PLANS FOR RADIO-TELEPHONE SERVICE WITH THE FAR EAST

As an initial step in its program of extending transoceanic telephone service into the Pacific region, the American Telephone and Telegraph Company has applied for a construction permit to erect a short-wave radio-telephone station in California. This station is designed to connect the United States with various countries bordering the Pacific and its island groups, as radio-telephone stations are equipped in the distant countries.

As now planned the first regular

service will be provided to the island of Oahu, in the Hawaiian group. By 1932 it is expected that all subscribers of the Mutual Telephone Company of Honolulu on the island will be within voice range of United States telephones. The proposed radio link to Hawaii will extend the talking range from the United States 2,100 miles westward. Telephone administrations of other countries in the Pacific area have likewise expressed an interest in the proposed service. In time it is probable that direct telephone connections will be established with Australia, Japan and others of the more important nations in the Far East.

For some time past company engineers have been investigating various sites on the West Coast to determine the best locations for the new radio stations, and several possibilities are under consideration. Once the question of location is settled, the work of erecting and equipping the two stations will go forward rapidly. The construction cost, including purchase of land, manufacture of apparatus, erection of buildings and radio towers and installation of equipment, will reach a total of over \$1,000,000.

Smooth Sailing DEMANDS Control

Regattas are won when Control is at the Helm. Every carefree gust of wind must be controlled . . every sail bellying properly, working the sloop smoothly, surely around the final buoy and down the last leg, the winner. In millions of homes radio skippers are cruising around the dials with CENTRALAB Controls at the helmsman's hand.

With Centralab Control at the helm, there is always smooth, noiseless reception. Be sure it's a CENTRALAB Control.

Send 25c to Dept. 140-D for new Volume Control Guide

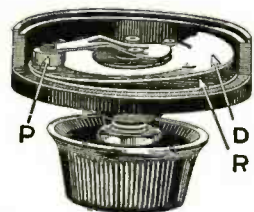

This shows the exclusive rocking disc construction of Centralab volume control. "R" is the resistance. Contact disc "D" has only a rocking action on the resistance. Pressure arm "P" together with shaft and bushing is fully insulated.

Centralab

CENTRAL RADIO
Dept. 140-D, 20 Keefe Ave.

LABORATORIES
Milwaukee, Wis.

A NEW TUBE IN GERMANY

AT the Berlin, Germany, radio show held recently one new development shown is a vacuum tube of an old design, remodeled and modernized.

The tube, which, because of its shape, has been called the Telefunken "rod" or "staff," is distinguished from the usual tube by having no grid, the control being exercised by an external metal coating. The idea is not new, as deForest patented this in 1906, a year before it occurred to him to insert a grid between the anode and cathode. With a tube of the ordinary shape the amplification is too small to make the idea practicable, hence the peculiar construction which has been adopted. The glass tube, about 4 or 5 inches long, is squashed flat, while the cathode consists of a straight filament running from top to bottom at one side of the flattened section, and at the other is the anode of sheet metal bent into an oval shape and pinched by the glass walls, thus giving it mechanical support. The control electrode consists of a metal coating squirted on to the glass and entirely



New German "Bar" tube.

surrounding it. It is impossible to obtain static characteristic curves for such a tube, because if a positive voltage be applied to the coating it attracts a negative electron charge on the inner wall, which neutralizes its effect. For the same reason the grid bias is of no account, and one can connect the coating directly to the anode of the preceding tube without any condenser, which simplifies and cheapens the radio receiver in which it is used. For high-frequency amplification and detection the tubes are made soft, but for audio-frequency amplification they are made with a high vacuum. The type of glass employed for making the tube is important, since the insulation resistance and consequent leak through the glass wall between the outer coating and the inner layer of ions and electrons plays an important rôle; it is this leak that makes the gas-filled tube unsuitable for audio frequencies. One rather unexpected but important advantage of this tube is that the filament, which

takes 0.2 ampere at 1 volt, can be supplied with alternating current without any trace of hum. Notwithstanding this, it is claimed that it amplifies the low audio frequencies. This tube is not only cheaper than other types, but lends itself to the construction of inexpensive sets. Tubes of this type are fitted in the Telefunken 12 W three-tube receiver, and the circuit shows their use in the first two stages. A built-in four-pole loudspeaker is included in this receiver, and arranged for public service working.

SPEAKING ABOUT THAT 1930-31 PRODUCTION

(Concluded from page 32)

and not thrown at the public. From some quarters comes the suggestion for a patent pool as a very necessary measure to stabilize the industry. There is also the suggestion of establishing uniform credits. Credit, it seems, is the curse of the industry.

Several manufacturers have come back to the sound logic that broadcasting is the real foundation of the industry, and that more thought must be given to broadcasting activities in building up a sound market for radio sets. "By a more 'circus-like' publicity in newspapers regarding 'big' broadcasting events," states one large manufacturer, it is possible to resume what we know as prosperity in the radio industry. Another manufacturer suggests, "Radio Week and showing consumers that radios are worth their weight in gold because of educational entertainment and cultural development factors."

Still another factor in the resumption of a lively radio trade is the creation of proper confidence for radio investments. With prices slashed right and left in the past, with list prices little more than just the basis to begin the bargaining process, the public has rightfully come to regard the radio set as one of the most meaningless investments made in household things. The radio set has been worth its weight in gold, so far as entertainment, cultural and other values are concerned, but from the standpoint of the radio set itself, the value has been a joke. The industry has a big job ahead by way of restoring proper list prices, proper discounts, and the reputation of manufacturers, jobbers and dealers. Here and there the process of restoring confidence is under way. It will be slow, uphill work. But it can be done—if we stick to it.

Let's cheer up and go to work. That is the great antidote for depression, and the surest medicine for early recovery.

ENGINEERING THE BATTERY SET

(Concluded from page 40)

Makeup of Receiver Circuits

The circuit is composed of two conventional stages of screen-grid r-f. amplification, followed by a tuned detector stage of the condenser-leak type, which is followed by two stages of transformer-coupled audio amplification. The first stage is a standard single-tube circuit, while the second stage is of the push-pull type. The plate circuit resistances are of such a value as to reduce the plate voltage of the detector to about 67.5, that of the first stage audio tube to about 90 volts, and that of the shield-grids to a maximum of about 45 volts (67.5 for the new 2-volt series). All circuits are well filtered with by-pass condensers and chokes. The choke in the last audio stage has thus far been found necessary, but there is a possibility of reduction in the amount of filtering in the r-f. stages particularly if the r-f. amplifier is confined to two tuned stages. All resistors for biasing are calculated from the plate current ratings of the tube manufacturers at an operating voltage of 135. The automatic biasing action takes care of any excess voltage during the first few hours of operation. In the first test all tubes were of the 3.3-volt filament class. Two each of types -22A, -99 and -20 were used. In the second test, two each of the types -32, -31 and -30 were substituted.

The cost of production of a battery-operated receiver following the lines here described should not be materially greater than the average present battery set, while the many advantages are readily apparent. The photograph reproduced as Fig. 4 shows a suggested chassis plan of simple construction. Arrangement of the various units is such that wiring is reduced to a minimum.

Estimated costs of A and B battery maintenance show a figure of approximately 1½ cents per hour on the Burgess No. 18 receiver, against 4 to 5 cents per hour for the average present battery receiver.

All in all, the foregoing engineering data simply goes to show that much can be done by way of refinement and improvement of the battery type radio set. The large market waiting for a satisfactory and economical battery type radio set is, in reality, waiting for the proper engineering development to be made available. The merchandisers, fully aware of the marketing opportunity, are simply marking time for engineers to do their share, now that they can well spare some time from the highly standardized socket-power radio set designs.

In the battle for sales, every detail counts

by George Lewis, Vice-President
Arcturus Radio Tube Company

A FOOL-PROOF set, mass-production, an aggressive sales force and extensive advertising—all get their final test when your dealer demonstrates a set.

Right there, in the dealer's sales-room, all your careful planning is at stake. Right then, a detail like slow-heating tubes often discounts a lot of skillful engineering.

Arcturus Blue Tubes avoid the delay. They snap the program through in 7 seconds. That kind of action helps sell sets because it gives the right *first* impression.

And long after the sale, Arcturus Tubes continue building good-will through their clear, life-like reception and long life.

When you engage in the battle for sales, check every detail. *7-second action, clear tone, long life*—that's the Arcturus contribution to successful sale-closing demonstrations. Specify Arcturus Blue Tubes now, both for factory testing and standard set equipment. Their performance completes your selling plans.

Arcturus Radio Tube Co., Newark, N. J.

ARCTURUS
Quick Acting
RADIO TUBES

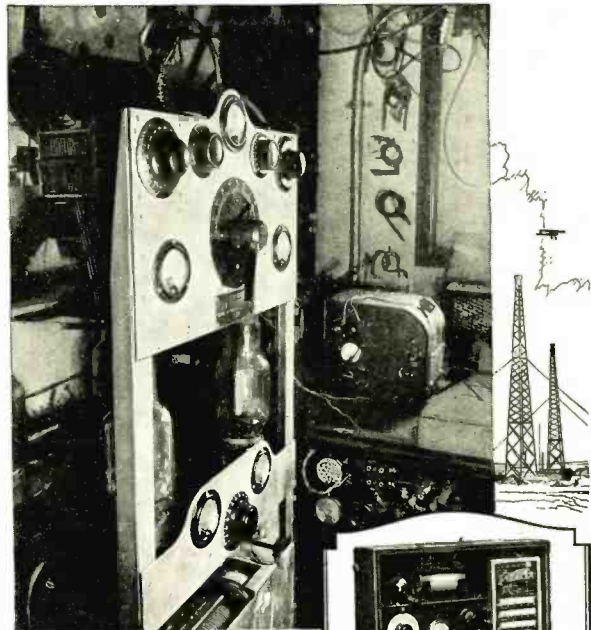

Showing eight of the many Weston Instruments used in the radio cabin on the "City of New York."

*in Westons,
Byrd
found the*



Three Weston Instruments were used on this portable radio transmitting and receiving set.

DEPENDABILITY he needed

WHEN Commander Byrd formulated plans for the long stay in the Antarctic, a very important task was the selection of equipment that would give service under the most adverse conditions.

There were no service organizations, factory representatives, nor extensive repair facilities in Little America; but a group of men, thousands of miles from civilization, whose lives and hopes depended upon the reliability of their equipment.

The 2" and 3 1/4" Weston D.C. and Thermo-couple Models were used by the Byrd Expedition.

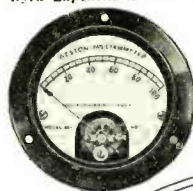

Only Radio could penetrate their isolation. It was radio that carried daily messages to the waiting world, that kept exploring parties in touch with Little America, and with Commander Byrd in his flight over the South Pole. And Weston points with pride to this important and unending radio service which was controlled with Weston instruments, instruments not made especially for the expedition but taken directly from our standard stock. Again Weston has kept faith.

Weston
PIONEERS
SINCE 1888
INSTRUMENTS
WESTON ELECTRICAL INSTRUMENT CORP.
612 Frelinghuysen Avenue Newark, N. J.

NEWS OF THE INDUSTRY

REDUCED INSULATOR BULK MAKES QUICK-HEATING TUBES

Ever since the heater type a-c. tubes were introduced, the heating time has been a mooted question. From the full minute required by some of the earlier heater tubes, the time has been cut to 15 or 18 seconds; but even so, the public has been looking for a heating time of the order of 8 to 10 seconds. However, heating time reduction must not be gained at the cost of life, hum, noise, microphonic freedom and other features. Too many quick-heating tubes have been found to pay too high a price for the few seconds saved. Hence the twin-hole tubes have continued in first place, despite their slow heating.

Through the development of a new insulating material which lends itself extraordinarily well to fine machining, it is now possible to provide a notched twin-hole insulator. The usual design of twin-hole tubing is notched at regular intervals along its length. The notches may be in a single line, or again on opposite sides of the tubing. At any rate, the bulk may be reduced 50 to 66-2/3 per cent, resulting in a remarkable heating time. The radio tubes including this notched erlite insulator heat in from 8 to 10 seconds. Meanwhile, all the advantages of the standard twin-hole tubing are retained, such as uniform heating without hot spots to cause premature breakdown; the wire is rigidly held even though exposed by the notches; maximum insulation is provided between the legs of the hairpin filament and cathode sleeve, according to Henry L. Crowley of West Orange, N. J.

THE USE OF "OILDAG" AS A RADIO PARTS LUBRICANT

The simplified tuning, made possible by the modern radio broadcast receiver, is accomplished by mechanical devices which must function with smoothness and precision.

Unlike the automobile, the radio receiver is not equipped with a lubricating system. Accordingly, the initial lubricant it receives at the time of manufacture should be durable and serve efficiently throughout the life of the set.

Failure or depletion of the lubricant promotes wear and permits the development of clearances which defeat the efforts of the designing engineers.

The efficient, durable, "graphoid" surfaces formed by Concentrated "Oildag," which are capable of functioning long after the oil carrier has been consumed, has created a demand for this lubricant among American manufacturers of radio receivers and receiver parts.

The Acheson Oildag Company is located at Port Huron, Mich.

MICROPHONE SERVICE

The Universal Microphone Co., Ltd., 1163 Hyde Park Blvd., Inglewood, Calif., have repaired several hundred carbon microphones for the National Broadcasting Company for the past year or more besides the repairs of other chains and countless numbers of individual stations. They solicit inquiries and correspondence on all microphone matters. They offer the free services of their engineering department as to special uses and installations for public-address, broadcasting, recording or technical work.

CONDENSER BULK AND LOW LIST PRICES

Weigh them! That advice applies just as forcibly to filter condensers as it does to storage batteries, when confronted with seemingly wide discrepancies between prices. Frequently, for condensers of presumably the same capacity and operating voltage, there will be a serious difference in prices, and yet the bulk and the weight will in very large measure determine whether both condensers are of equal intrinsic value so that prices may be accepted at their face value.

It is interesting to note that in the case of filter capacitors rated at 1000, 2000 and 5000 volts, the prices of various brands vary considerably. However, if one starts to analyze the matter, one finds that the size and general bulk of the lower priced units are considerably less than those of the higher priced units. It might be assumed that, on the one hand, the bulkier condensers were grossly over-rated, but this, we are assured, is not the case. No condenser manufacturer grossly over-rates his units, although some take no chances in attaining a fair service life of from six to ten years. On the other hand, it might be assumed that some condenser manufacturers had found a means of building a more refined condenser of smaller bulk, but this is not the case. Hence the conclusion is that the smaller condensers do not represent a sufficient factor of safety. With

less dielectric strength, the smaller condensers are simply built down to a price.

The Dubilier engineers have recently checked over the relative bulk and weight of filter condensers on the market. They find that their units average approximately three times the bulk of low-priced filter condensers of presumably the same capacity and voltage rating. Which, according to Dubilier engineers, should be considered when discussing prices.

OXFORD SPEAKERS

Frank Reichmann, of the Oxford Radio Corporation, 2035 W. Pershing Place, Chicago, says:

"Oxford speakers are expensive, because they are built to give the most perfect recreation of sound possible, the finest radio music and voice reproduction known. Oxford believes a great musical instrument should be built regardless of price considerations. The higher cost is forgotten in Oxford's perfection of performance."

WILBUR B. DRIVER

The accompanying photograph is a likeness of Mr. Wilbur B. Driver, President of the Gilby Wire Company, of Newark, N. J.



WILBUR B. DRIVER, President, Gilby Wire Co.

Mr. Driver is one of the pioneers of the art of manufacturing alloy wires for resistance uses and other purposes in electrical and radio operations.

DETERMINING WATTAGE OF THE RADIO SET

Many radio set owners are at sea regarding the actual current drain or, to be more final, the actual cost of their radio entertainment. Also, in selecting the proper type of automatic line voltage regulator for the proper operation of their radio sets, they are at a loss to determine the wattage of their sets.

According to the engineering staff of the Clarostat Mfg. Co., the wattage of any radio set is readily computed by checking up on the wattage of the tubes. Thus the wattage for the various types of tubes runs as follows:

Type	Watts	Type	Watts
250	45	224	7
281	15	227	7
210	17	226	5
280	15	171	10
245	18	112	10

In selecting the proper type of automatic line voltage regulator, it should be noted that one type takes care of receivers consuming up to 100 watts, while the second type takes care of sets requiring between 100 and 150 watts.

The cost of operating the radio set may be readily determined by obtaining the total wattage and comparing same with the kilowatt-hour rate. Thus a 100-watt set, operating on a 10 cent kilowatt-hour rate, costs about 1 cent per hour to operate.

EISLER SEALING-IN CASE SUSTAINED

The Eisler Electric Corporation of Newark, New Jersey, advises that the corporation has again won a victory against the General Electric Company, in which the latter company sued Charles Eisler, and the Eisler Engineering Company, now known as the Eisler Electric Corporation, for infringement of a sealing method, essential in the manufacture of incandescent lamps and radio tubes. Judge Bodine of U. S. District Court, sitting at Trenton, New Jersey on December 21, 1928, ruled that the Eisler sealing-in method does not infringe on the patents held by the General Electric, relating to similar mechanism in the processes thereof.

EASTON COIL COMPANY

The Easton Coil Company, Easton, Penn., has established departments for the manufacture of transformers and wire wound resistors.

JESSE MARSTEN JOINS INTERNATIONAL RESISTANCE

The International Resistance Company of Philadelphia, Pa., announces the appointment of Jesse Marsten as chief engineer of the organization. Marsten, a graduate engineer, has had long experience in radio engineering. From 1917 until 1919 he was identified with the test department of the Marconi Wireless Telegraph Company, conducting tests on quenched spark transmitters, receivers, resonance transformers, choke coils and so on, and with the engineering department on circuit development for aircraft radiophone transmitters. When the Radio Corporation of America took over the Marconi Company, Marsten became identified with the RCA research department, which later became the technical and test department, working on radiophone transmitters, receivers, audio systems for broadcasting, including studio amplifiers, condenser microphones, portable amplifiers, equalization amplifiers, wire line repeaters, and so on. In 1925 he joined the Freed Eisemann Radio Corporation, working on development and design of socket power devices and receivers until 1927, when he became chief engineer. In 1929 the company was merged with the Chas. Freshman Co., and Marsten took charge of the engineering department of both companies supervising development and design of component parts as well as circuits.

Mr. Marsten brings to the International Resistance Company an invaluable experience and knowledge of circuits and resistor applications, so that the organization can serve the radio field to still better advantage.

INCA EXPANDS

The Inca Manufacturing Division of National Electric Products Corporation, with main factory and general offices at Fort Wayne, Indiana, has purchased the plant and equipment of the S. & L. Manufacturing Company, located at 1547 Venice Boulevard, Los Angeles, California. The plant occupies a spacious brick building with floor space of 15,000 square feet.

The Inca Manufacturing Division has become an outstanding source of supply of copper products, especially of magnet wire and coils for the radio industry, and the news of the extension of its manufacturing facilities to Los Angeles will be received with interest by the radio trade of the entire Pacific coast.

ALUMINUM

The Aluminum Company of America, Pittsburgh, Penn., has issued a new booklet entitled "Alcoa Aluminum Die Casting." The booklet deals with the qualities of aluminum castings and gives considerable useful engineering information.

Designed to meet today's requirements and tomorrow's



No. 590—590



No. 2880—2880



No. 890



No. 280—280



No. 1880—1880

Frost-Radio Volume Controls are designed by forward-looking engineers whose ability comprehends tomorrow's problems as well as today's requirements.

Precision standards always have been a fundamental of Frost-Radio construction. These have enabled us to successfully meet any set manufacturer's requirements as to curve. They also have enabled us to banish noise from wire-wound models. And they have made possible a very much higher standard of efficiency in receiver operation.

If you would like to know more about the resources of this organization of specialists whose studies have so greatly aided the entire radio industry, we suggest you write us today, telling us fully of your requirements. We should like to place in your hands a recently prepared treatise on Volume Controls, a copy of which will be mailed on request.

HERBERT H. FROST, Inc.
Main Offices and Factory: Elkhart, Ind.
160 North LaSalle Street, Chicago

HERBERT H. FROST, Inc.
ELKHART, INDIANA

Please send me your complete treatise on the subject of noiseless wire-wound Volume Controls.

Name.....
Firm Name.....
City..... State.....

Now

A NEW PATENTED CONSTRUCTION PRINCIPLE



U. S. PATENT NO. 1775705

EVERLOCK washers and terminals have a new patented locking feature which is the secret of the tenacious grip and the positive lock.

EVERLOCK steel washers are coated after fabrication to prevent rusting.

EVERLOCK terminals are hot solder coated which makes them easy to solder and speeds up production.

Our manufacturing methods make it possible to quote prices in keeping with present economy programs.

We manufacture

- EVERLOCK washers
- ..
- EVERLOCK terminals
- ..
- Eyelet terminals
- ..
- Plain terminals single or double
- ..
- All are hot solder coated after fabrication
- ..
- Special terminals made to order
- ..
- Send us your specifications

THOMPSON-BREMER & Co.
1750 Carroll Avenue .. Chicago

WASHERS Everlock TERMINALS

NEW DEVELOPMENTS OF THE MONTH

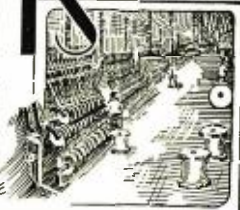

NEW TYPE SHORT-WAVE SHIELDED GANG CONDENSERS

A series of completely shielded gang condensers for broadcast frequencies, short-wave condensers and coils, as well as complete r-f. units and components for radio and audio-frequency amplification comprise the new group of products recently developed by the laboratory of the Hammond Manufacturing Company, 424 West 33rd Street, New York City, which are now available to the public.

The shielded condensers are offered in the two, three and four gang style, all having a maximum capacity of 370 mmf. The short-wave condensers are designed in capacities of 100, 125 and 150 mmf. maximum. In each of the two type short-wave coil sets, there are five coils, permitting tuning from as low as 14 meters to as high as 205 meters, with perfect blending of each band of frequencies. Both the gang and short-wave condensers have the "Midline" tuning characteristics. Newly developed three-stage band filter and radio-frequency units, first and second stage and push-pull audio-frequency transformers, filter chokes of 30 and 40 henrys inductance, and a filter condenser and power transformer are among the new radio and audio equipment.

The shielded gang condensers are extremely light and compact, yet very rugged with rigid 1/16 inch aluminum plates shielding each section. The light-weight and compact features are made possible by the use of a die-cast aluminum alloy frame and aluminum rotor and stator plates.

SINGLE SPOOL WINDER

The Eisler Electric Corporation, Newark, N. J., rate that their new machine No. 7, MS, a movable single spool wire winding machine has a distinct advantage over other makes of machines. When coated wire is being spooled the guides have a tendency because of their reciprocating motion to scrape off a small amount of coating.

In order to avoid this, the new type machine has been designed and operates in this manner: The spool itself moves back and forth, the guide remaining fixed; this of course permits the wire to run straight and directly on to spool, preventing any scraping.

The length of movement of spool depends on cam motion; this is readily made to suit requirements from 1 to 4 inches. Machine is also equipped with reset counter, denoting number of revolutions of spool.

GANG TYPE METALLIZED RESISTORS

Where compactness and simplicity are prime requisites, the gang type metallized resistor unit is certain to prove popular. This unit comprises the necessary number and values of standardized metallized resistors mounted on a strip by means of lead tips passing through holes in the strip and crimped on soldering lugs on the reverse side, making for ready wiring. Thus all resistors required for plate and grid-biasing requirements of a receiver may be mounted in a minimum of space, with the simplest form of wiring.

The gang type unit, recently developed by the International Resistance Company of Philadelphia,

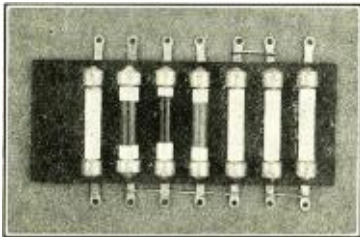

Pa., is meeting with widespread acceptance among set manufacturers, particularly the West Coast manufacturers of small console or so-called mantelpiece receivers where compactness, simplicity and low cost are prime considerations.

Obviously, the resistors may be supplied in practically any resistance value, and in a wide range of current-handling capacities to meet the requirements of electric or battery type receivers.

PHONOGRAPH MOTORS

The Hammond Clock Company, 2911 N. Western Avenue, Chicago, Ill., manufactures electric phonograph motors which are meeting with wide favor.

The Hammond perfect pitch phonograph motor is a new development in electric phonograph motors for home use, differing widely in design from anything which has preceded it.

The motor, which is of the synchronous type, was developed by The Hammond Clock Company through inventions and experience acquired in the manufacture of synchronous motors used in the construction of Hammond synchronous electric clocks. Like the clock motor, the phonograph motor has a constant and predetermined speed of rotation which is far more accurate than that obtainable by means of mechanical governors.

The accuracy of speed of the phonograph motor makes it possible to reproduce music at the precise pitch at which it was recorded, making it possible to reproduce a symphony, for instance, in the key from which it takes its name. The phonograph can then accompany the piano, saxophone, or other instruments which cannot be tuned.

While synchronous motors are used with success for operating phonograph turntables for talking movies, and in other elaborate apparatus, they have not been available at a cost low enough for popular use in the home except in a form which has not been satisfactory.

NEW BAKELITE SWITCH PLUG

The Eagle Electric Mfg. Co., Inc., of 50-79 Hall St., Brooklyn, N. Y., announces a new appliance switch plug-in bakelite. It is small, neat in appearance and very compact. The switch mechanism is of sturdy construction assuring long-life operation. The same heat resisting phosphor bronze contact clips used successfully in their other types of plugs are embodied in the construction of this new bakelite switch plug. Intended retail price 40 cents each.

TAPE DISPENSER

Jelinson and Johnson, New Brunswick, N. J., announce a new adhesive tape dispenser especially designed to speed tape application. Heretofore, it has been necessary to cut adhesive



tape and mount it on racks which are delivered to the operator as the tape is needed. By using this dispenser, all pre-handling is eliminated and the actual cost of using adhesive tape is thereby eliminated.

OUTDOOR AMPLIFIER

What is believed to be the last word in outdoor amplification has just been completed at Luna Park, Coney Island, by engineers representing the Macy Manufacturing Corporation of Brooklyn, N. Y.

Ten huge size horns hidden in recesses along the midway buildings completely spray the fifty-acre park with frequent band concerts while a continuous all-day program is interspersed with prominent radio broadcasts, recordings and feature artists of Luna. Announcements are clearly heard above the din and roar of the various rides within the park.

Two of the horns are mounted on the main crescent gracing the entrance of the park where the famous Arthur Pryor formerly conducted, and from the center of the park, selections of famous composers are rendered in a unique guessing contest.

The arresting feature of this broadcast is the realistic portrayal of the composer whose piece is played by the phantom orchestra while a makeup artist conducts before a looking glass in perfect synchrony with the music which emanates from the huge amplifiers of sound.

Baseball enthusiasts were pleasantly surprised in the first test when the scores were broadcast over the system by their favorite announcer.

MIDGET SET ACCESSORIES

The recent and unprecedented popularity of the midget set in the radio field has brought about a great demand for especially designed radio parts. Crove Name Plate & Manufacturing Company, 1749 Grace Street, Chicago, Ill., has been among the first to recognize and meet this demand with a well balanced selection of midget set accessories.

Special dials and drums have been engineered especially for the new type midget radio; one of the



most popular of these, the number 29 Drum, is here shown. A variety of escutcheons to fit these dials, together with scales, both metal and pyralin, make a complete range of tuning units for this type of radio receiver. Several new developments in tuning devices will be announced by Crove in the near future.

Crove Name Plate also manufacture sub-bases for midget radio sets.

TURNTABLE MOTOR

The Diehl Manufacturing Company, Elizabethport, N. J., announces a new turntable motor. The announcement reads:

"The new Diehl 'Aristocrat' turntable motor is the development of several years' experience in supplying Diehl motors to the foremost radio-phonograph combination set manufacturers as standard equipment for their machines. It incorporates many novel features of design and construction and combines small size and lightness of weight with a power output considerably in excess of all normal requirements.

"Attractively finished in durable black lacquer, with all steel parts heavily nickel-plated to prevent rust, and fittings finished in statuary bronze, the 'Aristocrat' is distinctive in appearance and will harmonize well with any piece of equipment to which it is applied.

"Its substantial design and construction, the result of more than forty years of motor building experience, insures trouble-free operation for a long period of time with no care or attention other than occasional lubrication.

"The new Diehl automatic stop, a device of unusually simple and efficient design, is supplied with each 'Aristocrat' motor, unless otherwise specified. Furnished completely assembled and wired to the motor, its installation merely requires the fastening of two screws. No connections to be made, no holes to be drilled in the motorboard and no loose parts to be lost."

NEW PHOTOGRAPHIC FLASH LAMP

A new photographic flash lamp for connection by cord to house circuits has been brought out by the General Electric Company.

The new lamp will in time replace flashing powders heretofore universally used. The lamp is used but once, a new lamp being required for each picture.

ANTENNA WIRE

The Holyoke Company, Inc., 621 Broadway, New York, has introduced a combination antenna, lead-in and ground wire, which has numerous excellent features.

REPLACEMENT TRANSFORMERS by THORDARSON

Replacement Power Transformers

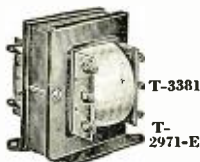

T-3381 for single "171" tube in output stage. T-2971-E for "171" push-pull tubes in output stage



for "245" push-pull tubes in output stage
Replacement Input Transformer



for push-pull tubes in output stage
Replacement Audio Transformer



R-100

Install tone quality in unsatisfactory sets by replacing inferior, obsolete, or worn out units with THORDARSON REPLACEMENT TRANSFORMERS . . . it is what the set owner hears . . . the improvements in audio amplification . . . that makes pleased customers.

THORDARSON Replacement Transformers are constructed according to the true high standards set by all THORDARSON apparatus . . . and they are almost universal in application.

A small stock of THORDARSON Replacement Transformers enables you to recondition a wide variety of sets, with minimum investment in stock. For sale at all good Parts Dealers everywhere.

SEND TODAY for the new catalog of Replacement Power and Audio Transformers.

THORDARSON

TRANSFORMER SPECIALISTS SINCE 1895 . . .

Thordarson Electric Mfg. Co.
Huron, Kingsbury and Larrabee Streets, Chicago, Ill.

AN EFFICIENT, HEAVY-DUTY
▶ RECTIFIER TUBE ◀

EVEREADY RAYTHEON **B-H**
FOR "B" ELIMINATOR UNITS



Type B-H
125 m. a.
at 300 volts

IF YOU use a "B" eliminator, a new Eveready Raytheon B-H will put a lot more punch in your radio set. Most "B" power units — more than 100 different makes — are designed for this famous tube.

The B-H is the original gaseous rectifying tube for such units. It uses ionized helium instead of a filament — supplying millions of electrons a second, over and over. This means long life, high efficiency, sustained voltage over a long period.

Note to experimenters: If you need a source of steady, powerful, dependable D.C., you will find it in the Eveready Raytheon B-H.

★ ★ ★

The Eveready Hour, radio's oldest commercial feature, is broadcast every Tuesday evening at nine (New York time) from WEAJ over a nation-wide N. B. C. network of 30 stations.

NATIONAL CARBON COMPANY, INC.

General Offices: New York, N. Y.

Branches: Chicago, Kansas City, New York, San Francisco

Unit of Union Carbide **UCC** and Carbon Corporation



Trade-marks

NEW MIDGET RADIO

The new model "82" Jackson-Bell Midget which has just been placed on the market by the pioneer Pacific Coast manufacturer of the same name has many distinctive features which, according to the manufacturer, will place it in a field apart. One of the outstanding features of the set is its tone-control, an original Jackson-Bell development. Another one of the features of the new set is its perfect harmony of line in the cabinet work. It slips unobtrusively into any setting.

The Model "82" receiver contains six tubes, four type 224 screen-grid, one type 245 power tube and one type 280 rectifier. It has three stages of tuned radio-frequency amplification with four tuned circuits and screen-grid power detector. It contains only one stage of audio-frequency amplification, which is resistance-coupled to the detector. The radio-frequency circuit is known as a "constant gain" circuit, in which the amplification and selectivity over the entire broadcast band remain practically constant. The selectivity of this receiver is not appreciably affected by the length of antenna used.

Tuning is controlled by a single illuminated dial operating a four-gang condenser. Volume control and switch are combined in one unit. The set is equipped with tone control, which is operated by a knob in front of the panel.

RADIO CHASSIS

The Acme Electric and Mfg. Co., 1444 Hamilton Avenue, Cleveland, Ohio, announce the introduction of an eight-tube radio chassis kit, for custom set builders.

FELT

The Aetna Felt Company, 200 Center Street, New York City, now manufactures a line of cut, pressed felt parts for the radio industry, consisting of washers, gaskets, turntable felts, and a line of woven felt parts made in all thicknesses. Thicknesses can be held to one one-thousandth inch.

MUSIC REPRODUCING SYSTEM ADDS TO THE CHARM OF MINERAL BEACH

Mineral Beach, located near Pittsburgh, Pa., is one of the largest and most beautiful swimming pools in Western Pennsylvania. The natural advantages of this pool are cleverly enhanced by the architectural design and still further improved by the installation of an ultra-modern sound amplifying system. The apparatus used comprises radio, phonograph and microphone input.

These three are controlled through a system of selective switching which is very plainly marked and easy to operate. In fact, the girl who acts as cashier, also operates the sound amplifying equipment.

The amplifier includes a two-stage Samson PAM-5 which may be operated from the output of the detector tube of the radio set, from the output of the phonograph pick-up or from a Samson M1K 1 microphone amplifier. The PAM-5 supplies an input signal to two Samson PAM-25's. These are powerful single stage amplifiers, each utilizing two 250 tubes in push-pull. A Samson Qualensator for controlling tone, adds to the effectiveness of this installation.

In addition to the monitor speaker which is equipped with a separate volume control, the output circuit carries five Wright-DeCoster No. 107 dynamic reproducers. Three of these speakers are used with Wright-DeCoster No. 9 horns placed on the roof of the bathhouse, while the other two are mounted on baffles and hung in the dance hall. Ellis two-button microphones are used for making announcement.

VACUUM PUMPS

The F. J. Stokes Machine Company, Olney Post-office, Philadelphia, Penn., has issued bulletin No. 149 describing the Company's high vacuum pumps.

The Stokes high vacuum pump is the result of over 30 years' experience in vacuum engineering and is built for lasting, dependable service. As the air is completely discharged at the end of each stroke there is no re-expansion to impair the pump's efficiency. With the suction line blanked off, the vacuum produced is within .01 millimeter (10 microns or .0004 inch) or better. The pump is very practical and efficient for commercial vacuum service of all kinds.

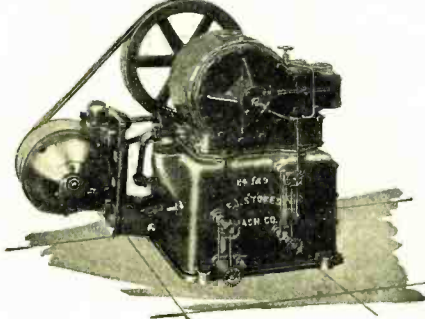

A NEW RESISTANCE UNIT

Hardwick, Hindle, Inc., Newark, N. J., are offering their new enameled slide resistor—a new device which combines the ruggedness and high wattage of the vitreous enameled resistor with the convenience of being continually adjustable.

Along the surface of a refractory tube is space-wound a resistance wire having a low temperature co-



efficient of resistivity, with suitable terminals at both ends. This assembly is then enameled with a vitreous coating by a special process, which leaves a small arc of the upper surface of the turns exposed along a straight narrow track. A suitable adjustment band and shoe are employed to furnish contact with the coil at any desired point.

IMPROVED AMERTRAN AUDIO TRANSFORMERS

During the Radio World's Fair in New York City, the American Transformer Company announced its new and improved line of AmerTran de luxe audio transformers. These units are now available in a greater number of types and sizes than ever before and they have been redesigned to live a still longer, more useful, and trouble-free life by use of an improved mounting which provides absolute protection against moisture. In addition, many models are capable of even greater fidelity of tone.

The enlarged line of AmerTran audio transformers consists of 34 standard models—a type for every amplifier requirement, including large concert-hall amplifiers as well as radio receivers. Among the types available are: six input, five interstage, seventeen output, and six mixer transformers. Special high-permeability alloy is used in the core laminations in all cases, and the core structure employed provides low distributed capacity, low capacity coupling, and high inductance coupling. Where center-tapped connections are employed these are brought out between sections or coils which are so arranged as to give exceptional magnetic and inductive symmetry and balance.

The American Transformer Company bulletin No. 1050 describes these items in greater detail.

tone control for every radio set

That outstanding feature of 1930 radio sets, the tone control, is now made available to owners of any and all radio sets irrespective of type or vintage. In the Clarostat* tone control, introduced by the Clarostat Mfg. Co., Inc., Brooklyn, N. Y., there is provided a universal device applicable to a radio set by the simple expedient of slipping the disc connectors around the prongs of both power tubes in the push-pull type, or around the prongs of the power tube and connecting the other lead with the ground binding post.

The device is in the form of a neat case with felt bottom, for use on any table or on top of the set cabinet, together with two long flexible leads terminating in the connectors, so that no tools or special knowledge are necessary for installation. A knob turns from the "Trebble" to the "Bass" positions, providing any degree of sharpness or mellowness desired.

THE PHONOMATIC

To fulfill the demand for an automatic phonograph unit of simple, practical inexpensive design the White Research Laboratories, 33rd and Arch Sts., Philadelphia, Penn., designed a new Phonomatic.

It will play either 10 or 12 inch records of any standard make. It is possible to mix 10 and 12 inch records on the turntable at the same playing. By a turn of the repeat knob any record can be repeated any desired number of times. The machine can also be stopped at any time and records removed or added.

Pump for high Vacuum

AMPLION SOUND EQUIPMENT USED AT PAVONIA TRICENTENARY CELEBRATION

Three hundred years ago, a territory which now embraces several counties, was established by the Dutch as the patronship of Pavonia. The most populous part of what was once Pavonia is now Jersey City, N. J., a municipality of 330,000 population. The Pavonia Tercentenary was celebrated from September 21 to September 27 by Jersey City residents and visitors from all over the country.

In order to make sure that all the important features of this celebration could be heard as well as seen by the vast throngs in attendance, two complete Amplion group address systems were installed.

At Lincoln Park, an enormous outdoor stage was constructed. Loudspeakers were put up on both sides of the proscenium. The equipment at each side consisted of two Amplion giant dynamic units with 12-ft. exponential horns and a single giant dynamic unit equipped with two 6-ft. trumpets. The amplifying apparatus consisted of two 50-watt amplifiers mounted on a vertical panel and connected so as to supply 100 watts. Provision was made for microphone, phonograph and radio input.

Amplion microphones were installed on the stage, at the band-stand and at other strategic points. The microphone input amplifier was located in the small control room with the 50-watt amplifiers.

This sound amplifying system enabled audiences of over 50,000 people to hear the entertainment and speeches with the utmost clarity. Even those furthest from the stage had no difficulty whatsoever in hearing and understanding every part of the program.

At Journal Square, an Amplion portable group address system was used at the reviewing stand. Here, the 50-watt portable amplifier was used, together with a portable microphone input amplifier. Six 6-ft. Amplion trumpets were mounted twelve feet above the platform and directed so as to cover an angle of 180 degrees.

It was possible to hear the Journal Square band distinctly from Lincoln Park, over one-half a mile away and out of line of the trumpet speakers.

VARNISH CONTROL UNIT

The John C. Dolph Company, 163 Emmett St., Newark, N. J., has produced an efficient varnish control unit as an added service to insulating varnish users. The outstanding functions of this unit are as follows:

1. It mechanically reduces the varnish thoroughly and quickly by circulation.
2. It filters the varnish

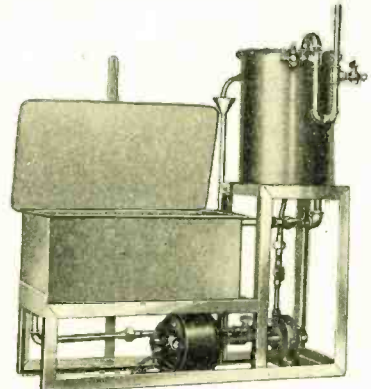

during every reducing operation. 3. It mechanically stores the varnish in a tank, sealed to prevent oxidizing reactions and loss of solvent thru air contact. 4. It supplies a dipping tank that can be quickly emptied when dipping work has been completed.

The new unit ranges from the one drum size (55 gallon capacity) up to and including the six drum size (330 gallon).

ELLIS DEMOUNTABLE MICROPHONES

This invention is the latest achievement of the engineers of the Ellis Electrical Laboratory. This demountable feature is obtainable in the standard models of the Ellis Models Nos. 29N and 30N.

The Ellis demountable microphone was designed for convenience and safety—safety from fire and from exposure to the elements. These purposes are attained by making the microphone unit easily and quickly removable or "demountable" from the supporting fixtures and easily replaceable.

The value of this improvement in the microphone field will be appreciated by those whose patience has been taxed by the clumsy and burdensome task of removing a microphone, locating a screw-driver to disconnect and reconnect the wires, unlacing and relacing a tight set of springs, and being careful to avoid mistakes in reconnecting the cable.

There are many cases where it proves to advantage to use the very sensitive Model 29N for the speaking voice and then change to the Model 30N for music. This is an easy matter with the Ellis demountable and is especially important in the production of talking films both in the studio and in the field.

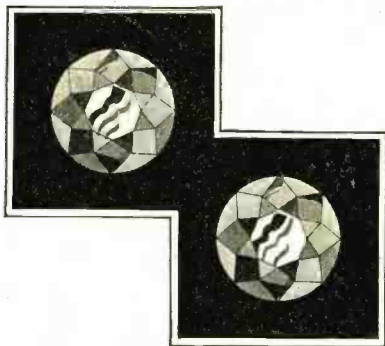

**They Look Alike
yet
One Has A Flaw**

IDENTICAL appearance does not guarantee perfection in radio tube parts any more than in the two diamonds. Tube manufacturers must depend on the experience and reputation of the parts makers for their accuracy and quality. It is significant therefore, that leading vacuum tube manufacturers specify parts by Radio Products Corporation.

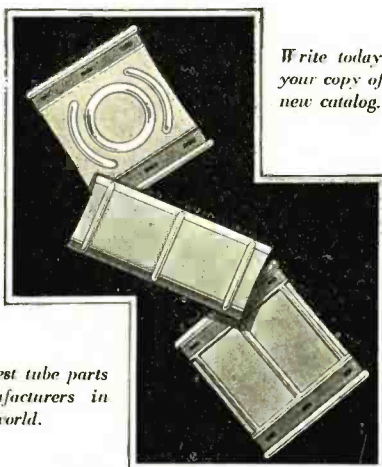

Write today for your copy of our new catalog.

Largest tube parts manufacturers in the world.

RADIO PRODUCTS CORP.

548 SOUTH 11th STREET, NEWARK, NEW JERSEY
17 Southampton Street, London, WC-I, England

**Do you receive
“The Allied
Die Caster”?**

“The Allied Die Caster” is a magazine published every month and sent, without obligation, to all those who have indicated an interest in the production economies possible by the die casting process.

“The Art of Die Casting” is now being thoroughly covered in a series of articles—one every month—for the purpose of acquainting the readers of “The Die Caster” with the die casting process, as developed by Allied—its

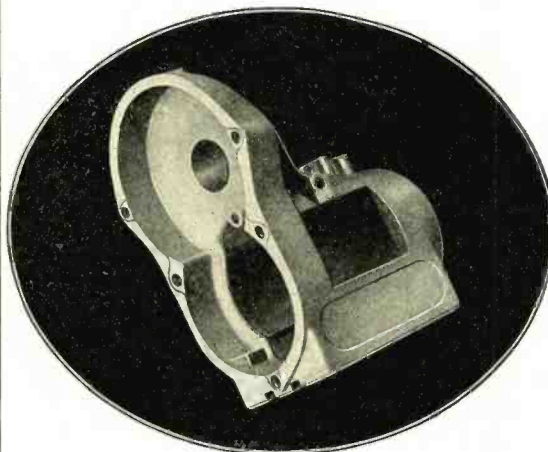

possibilities for reducing costs and how these possibilities can best be used to advantage.

The magneto housing shown is just one illustration of how die casting reduces the production of parts, which formerly required numerous costly operations, to a single major operation. This part, intricate in design, containing several steel inserts and requiring extreme accuracy, was produced at a price not possible by any other process.

If you are not receiving your copy of “The Die Caster,” a letter giving us the names of the executives who should receive it, will bring it regularly without charge.

**ALLIED DIE CASTING
CORPORATION**

43rd Avenue from 38th to 39th Streets,
LONG ISLAND CITY, N. Y.

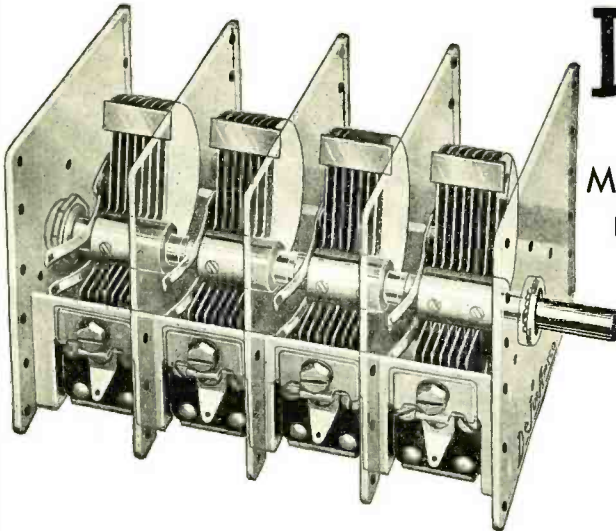

Write for engineering data and working drawings. Send us your specifications and let us quote. Samples on request.

We Also Make Special Condensers for
Automobile Radios and Portable Receivers

DeJur-Amsco

NEW 1930-31 SERIES

Multiple Variable Condensers

For Standard and Midget Receivers

This new DeJur-Amsco series of Multiple Variable Condensers is made in two sizes to meet the requirements of the manufacturers of standard and midget sets. Manufacturers of midget receivers were quick to avail themselves of DeJur-Amsco laboratory experience and service, and we are now supplying all the large midget set manufacturers.

Each size is made in one capacity and can be obtained in 2, 3, 4 and 5 gang units. These new condensers set a high standard for compactness, ruggedness and mechanical and electrical accuracy of design.

DeJur-Amsco Corp.

95 MORTON ST.
NEW YORK CITY

Build Your Own CAPACITY BRIDGE

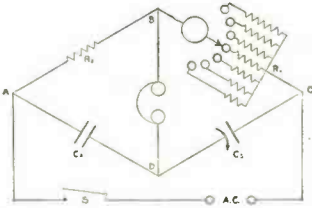

Super Akra-Ohm wire-wound Resistors are recommended for the construction of an inexpensive capacity bridge in September QST. The following Super Akra-Ohm Resistors, type 6M, were used:

1- 100 Ohm \$1.25 ea.	1- 10,000 Ohm \$1.50 ea.
1- 300 Ohm \$1.25 ea.	1- 30,000 Ohm \$1.50 ea.
2- 1000 Ohm \$1.25 ea.	1-100,000 Ohm \$2.00 ea.
1- 3000 Ohm \$1.25 ea.	



We manufacture wire-wound resistors of any value from 0.01 to 10,000,000 ohms having negligible inductance and distributed capacity and calibrated to an accuracy of 1%. Their use is highly recommended for Laboratory Standards, High Voltage Regulators, Telephone Equipment, Television Amplifiers, Grid and Plate Resistors, Electrical Apparatus, and Test Equipment, etc.

Prices range from \$1.25 for 100 ohms to \$4.00 for 500,000 ohms.

Send us your dealer's or jobber's name and we will send you a copy of an article reprinted from September QST telling how to build a capacity bridge. Address Dept. M.



Shalleress Mfg. Company

ELECTRICAL SPECIALTIES
700 PARKER AVENUE
Collingdale, Pa.



FINISH IT WITH



THE very important part of the value we contribute to Zapon is the pioneering experience that has led to the present day highly perfected development of

PYROXYLIN LACQUERS

Motivated by the same spirit as the pioneers of covered wagon days, we have blazed every scientific trail leading to the highest degree of pyroxylin lacquer quality and uniformity. Every experimental test, every chemical process, all research and basic materials have been brought directly under the complete control of our laboratories.

As a result users of pyroxylin lacquers for every known purpose, the world over, are finding there is no substitute for Zapon. No approach to its leadership, no comparison as to its results, its satisfaction and economy.

Behind the use or specification of this product stands a reputation that has made Zapon "The acknowledged standard since 1884."

Regardless of what your finishing problem may be, the complete facilities of our service laboratory are constantly at your disposal without cost. Let this scientific knowledge and experience aid you in the more practical and economical solution of your problem. We invite your inquiries.

THE ZAPON COMPANY

STAMFORD, CONN.

Subsidiary of Atlas Powder Company



THE Group Subscription Plan for RADIO ENGINEERING enables a group of engineers or department heads to subscribe at one-half the usual yearly rate.

The regular individual rate is \$2.00 a year. In groups of 4 or more, the subscription rate is \$1.00 a year. (In foreign countries \$2.00.)

The engineering departments of hundreds of manufacturers in the radio and allied industries have used this Group Plan for years, in renewing their subscriptions to Radio Engineering.

Each subscriber should print his name and address clearly and state his occupation—whether an executive, engineer, department head, plant superintendent, foreman or technician, etc.

Remember this Group Plan when Your Subscription Expires

(Radio Engineering)

Bryan Davis Publishing Co., Inc.,
52 Vanderbilt Ave.,
N. Y., N. Y.

Los Angeles

Chicago

Cleveland

Announcing— The **DAYRAD** No. 180 Test Oscillator

For Super-Heterodyne Adjustments



The increased demand for ultra sensitivity and selectivity require an accurate Oscillator. An output meter is needed to indicate the correct adjustments.

The DayRad Type 180 Test Oscillator is built with 2 ranges: 550 to 1500 kilocycles, and two fixed frequencies, 175 and 180 kilocycles. The 175 kilocycles setting is provided with a vernier permitting 5 kilocycles variation above or below the fundamental.

Accuracy is $\frac{1}{2}\%$ on intermediate frequencies; $\frac{1}{2}\%$ at 1400 kilocycles; 1% at 600 kilocycles. Output meter has 3 ranges.

Instrument is shielded and is provided with variable output control.

Licensed for amateur and expert use.

Net price to dealers \$57.50

For further information see your distributor or write

THE RADIO PRODUCTS COMPANY

DEPT. E

5th and Norwood

Dayton, Ohio

Escutcheons — DIALS and NAME PLATES



Our large and modern plant affords excellent facilities for the speedy production of your requirements in etched and lithographed; also embossed metal specialties. A large variety of stock dies enables Radio Manufacturers to effect great savings on escutcheons, for regular models, Midget sets, and auto radio sets.

Send your blueprints — our Art Department will gladly submit original sketches for your approval.

General Etching and Mfg. Co.
MANUFACTURERS OF
ETCHED AND LITHOGRAPHED METAL PRODUCTS
 3070-82 W. Grand Ave., Chicago, Ill.

JENKINS & ADAIR

MIXING CONTROLS

TYPE GM-10 AND GM-2

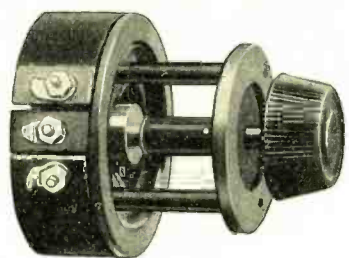

If your mixing system incorporates ordinary potentiometers as mixing controls you can materially improve the response characteristic by using our GM-2 or GM-10 mixer units. A three-channel system using GM-2 units has a maximum variation in attenuation of less than 1 DB between 50 and 6000 cycles for any setting of the mixing controls.

Jenkins & Adair units are compound wound and operated as modified T-type pads.



Price (in U. S. A.) F. O. B., Chicago, \$15.00. Mixing transformers for matching any type of circuit also supplied. Send for Bulletin 1-D and Supplement for full description.

JENKINS & ADAIR, INC.
ENGINEERS
 3333 Belmont Ave.
 CHICAGO, U. S. A.

CABLE ADDRESS: JENKADAIR TELEPHONES: KEYSTONE 2130

British Offices: 76 Old Hall St., Liverpool, England;
 40 Buckingham Gate, London, S. W. 1, England
 French Office: 16 Rue de Chateaudun, Asnieres, France

— TUBE SOCKETS — WITH TOP PLATES

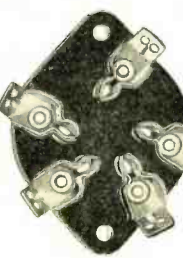



6980-AA TOP PLATES 6970-AA

TERMINAL STRIPS



6830-A



6950-A

Our plant and engineering facilities lend themselves to the production of special requirements on short notice. Inquiries solicited.

SORENG MANEGOLD CO.

771 Mather St. Chicago, Ill.

SYNTHANE

Laminated Bakelite

Dependable Uniformity
in Electrical and Mechanical Properties

DIELECTRIC STRENGTH
 LOW WATER ABSORPTION
 STRUCTURAL STRENGTH
 LOW SURFACE LEAKAGE
 CLEAN PUNCHING
 MACHINEABILITY
 IMPACT STRENGTH
 APPEARANCE

SYNTHANE

CORPORATION OAKS - PENNA

NEW YORK, CHICAGO, CLEVELAND, SAN FRANCISCO
 Sheets, Tubes, Rods, Fabricated Parts

We are Condenser Specialists
Send for new price list—just out

Igrad Condenser & Mfg. Co. *Home Office and Factory: Rochester, N. Y.*

Representatives:
 Aaron, Siedman & Co. Chicago, Ill.
 The M. Simons & Son Co. (Export) New York, N. Y.
 Dimond Sales Co. New York, N. Y.
 Marshank Sales Co. Los Angeles, Calif.
 Trade Contact Corp. Boston, Mass.
 A. L. Gillies Toronto, Canada

FOIL.

FOR
CONDENSERS
TIN, LEAD, ALUMINUM

OUR MANUFACTURING EXPERIENCE OF OVER 40 YEARS IS YOUR GUARANTEE OF QUALITY MATERIAL AND SATISFACTORY SERVICE

The Johnston Tin Foil & Metal Co.
 6016-6106 S. BROADWAY
ST. LOUIS, MO.
 EST. 1889

A QUIET DEPENDABLE POWER TRANSFORMER

Correct mechanical and electrical construction.
 Unique mounting and terminal design.
 No mechanical vibration.
 Winding baked in varnish.
 Low temperature rise.
 Size may be altered to meet individual requirements.

KINGSTON PRODUCTS CORPORATION
 KOKOMO, INDIANA

*Specialists in Power Transformers,
 Filter Condensers, Filter Reactors.*

KINGSTON

**Specialists In Power Transformers,
 Filter Condensers, Filter Reactors**

What's Your Trouble?

Is it solder? Few people realize just how much grief and trouble can come from using the wrong solder. For years our job has been prescribing and making the right solder. Perhaps we can help you. It won't cost anything for our advice and you will be surprised at what a difference **KESTER SOLDER** will make in both production and performance.

KESTER SOLDER
 INCORPORATED - 1899
COMPANY
 4224 Wrightwood Ave., Chicago

Buyers Directory of Materials and Apparatus

Readers interested in products not listed in these columns are invited to tell us of their wants, and we will inform the proper manufacturers. Address Readers' Information Bureau.

Addresses of companies listed below, can be found in their advertisement—see index on page 66.

- ALUMINUM:**
Aluminum Co. of America
Fairmont Aluminum Co.
- ALUMINUM, SHEET, FOIL:**
Fairmont Aluminum Co.
Johnson Tin Foil & Metal Co.
- AMMETERS:**
General Electric Co.
General Radio Co.
Weston Elec. Instrument Corp.
- AMPLIFIERS, POWER:**
American Transformer Co.
General Radio Co.
Samson Elec. Co.
- ANTENNAE, LAMP SOCKET:**
Dubilier Condenser Corp.
- ARRESTERS, LIGHTNING:**
Cornish Wire Co.
- BASES, SPEAKER:**
American Felt Co.
Booth Felt Co.
Western Felt Company
- BASES, VACUUM TUBE:**
(See Tube Parts)
- BINDING POSTS:**
General Radio Co.
- BOXES, STEEL:**
Angle Steel Stool Co.
- BRACKETS, ANGLE:**
Scovill Mfg. Co.
- BRASS:**
Scovill Mfg. Co.
- BROADCAST STATION EQUIPMENT:**
American Transformer Co.
Cardwell, Allen D., Mfg. Co.
General Radio Co.
Jenkins & Adair, Inc.
- BUSSES, STEEL:**
Angle Steel Stool Co.
- BUTTS:**
Scovill Mfg. Co.
- CABINETS, METAL:**
Aluminum Co. of America
- CASTINGS:**
Fairmont Aluminum Co.
- CELLS, PHOTOELECTRIC:**
National Carbon Co., Inc.
- CEMENT, LOUD SPEAKER:**
Maas & Waldstein Co.
- CENTRALIZED RADIO SYSTEMS:**
American Transformer Co.
Samson Elec. Co.
- CHAIRS, STEEL, FACTORY AND OFFICE:**
Angle Steel Stool Co.
- CHASSES:**
Aluminum Co. of America
Metal Specialty Co.
- CHOKES, AUDIO FREQUENCY:**
American Transformer Co.
General Radio Co.
Meissner Mfg. Co.
Polymet Mfg. Co.
Thordarson Elec. Mfg. Co.
- CHOKES, RADIO FREQUENCY:**
Cardwell, Allen D., Mfg. Co.
General Radio Co.
Hammarlund Mfg. Co., Inc.
- CHOKES, POWER:**
American Transformer Co.
Dongan Elec. Mfg. Co.
General Radio Co.
Meissner Mfg. Co.
Polymet Mfg. Corp.
- CLAMPS, GROUND:**
Clarostat Mfg. Co.
Scovill Mfg. Co.
- CLIPS, SPRING:**
Electrad, Inc.
Scovill Mfg. Co.
- CLOTH, WIRE:**
(See Wire Cloth)
- COIL FORMS:**
General Mfg. Co.
General Radio Co.
- COIL WINDING:**
Acme Elec. & Mfg. Co.
Automatic Winding Co.
Concourse Electric Co.
Dudlo Mfg. Co.
Easton Coil Company
General Mfg. Co.
Inca Mfg. Co.
Meissner Mfg. Co.
Polymet Mfg. Corp.
- COILS, CHOKE:**
Acme Elec. & Mfg. Co.
Dudlo Mfg. Co.
Easton Coil Company
Polymet Mfg. Corp.
- COILS, IMPEDANCE:**
Dudlo Mfg. Co.
Easton Coil Company
General Mfg. Co.
Polymet Mfg. Corp.
- COILS, INDUCTANCE:**
Cardwell, Allen D., Mfg. Co.
Easton Coil Company
General Radio Co.
Hammarlund Mfg. Co.
Inca Mfg. Co.
- COILS, MAGNET:**
Acme Wire Co.
Dudlo Mfg. Co.
Easton Coil Company
Inca Mfg. Co.
Polymet Mfg. Corp.
- COILS, SHORT WAVE:**
Easton Coil Company
General Mfg. Co.
General Radio Co.
Hammarlund Mfg. Co.
- COILS, TRANSFORMER:**
Acme Wire Co.
Dudlo Mfg. Co.
Easton Coil Company
Meissner Mfg. Co.
Polymet Mfg. Corp.
- CONDENSER PARTS:**
Aluminum Co. of America
Henry L. Crowley & Co.
Metal Specialty Co.
Scovill Mfg. Co.
- CONDENSERS, BY-PASS:**
Aerovox Wireless Corpn.
Amrad Co.
Condenser Corp. of America
Dongan Electric Mfg. Co.
Dubilier Condenser Mfg. Co.
Igrad Condenser & Mfg. Co., Inc.
Polymet Mfg. Corp.
Potter Co., The
Sprague Specialties Co.
- CONDENSERS, ELECTROLYTIC:**
Aerovox Wireless Corp.
Amrad Corporation
Condenser Corp. of America
Polymet Mfg. Co.
Sprague Specialties Co.
- CONDENSERS, FILTER:**
Aerovox Wireless Corpn.
Amrad Co.
Condenser Corp. of America
Dongan Electric Mfg. Co.
Dubilier Condenser Corp.
Igrad Condenser & Mfg. Co., Inc.
Kingston Products Corp.
Polymet Mfg. Corp.
Potter Co., The
Sprague Specialties Co.
- CONDENSERS, FIXED:**
Aerovox Wireless Corpn.
Amrad Corporation
Concourse Elec. Co., Inc.
Condenser Corp. of America
Dongan Electric Mfg. Co.
Dubilier Condenser Mfg. Co.
Polymet Mfg. Corp.
Potter Co., The
Sprague Specialties Co.
- CONDENSERS, MIDGET:**
Cardwell, Allen D. Mfg. Co.
General Radio Co.
Hammarlund Mfg. Co.
Polymet Mfg. Corp.
Scovill Mfg. Co.
Sprague Specialties Co.
United Scientific Laboratories
- CONDENSERS, MULTIPLE:**
Cardwell, Allen D. Mfg. Co.
Hammarlund Mfg. Co.
Scovill Mfg. Co.
United Scientific Laboratories
- CONDENSERS, NEUTRALIZING:**
Hammarlund Mfg. Co., Inc.
Polymet Mfg. Corp.
- CONDENSERS, VARIABLE TRANSMITTING:**
Cardwell, Allen D. Mfg. Co.
DeJur-Amsco. Corp.
General Radio Co.
Hammarlund Mfg. Co.
Jenkins & Adair, Inc.
- CONDENSERS, VARIABLE:**
Cardwell, Allen D. Mfg. Co.
Concourse Elec. Co., Inc.
Frost, Herbert H., Inc.
General Radio Co.
Hammarlund Mfg. Co.
Scovill Mfg. Co.
United Scientific Laboratories
- CONNECTORS:**
Cornish Wire Co.
Scovill Mfg. Co.
- CONTAINERS, BATTERY BOX:**
George F. Mitchell & Sons Co.
- CONTROLS, CURRENT:**
Central Radio Laboratories
Polymet Mfg. Corp.
Shallcross Mfg. Co.
- CONTROLS, VOLUME:**
American Transformer Co.
Central Radio Laboratories
Clarostat Co.
Ferranti, Inc.
Polymet Mfg. Corp.
Superior Resistor Co.
- CONVERTERS:**
Cardwell, Allen D., Co.
Electric Specialty Co.
- CONVERTERS, ROTARY:**
Electric Specialty Co.
- COPPER:**
Scovill Mfg. Co.
- CORDS, EXTENSION:**
Baconda Wire & Cable Co.
Cornish Wire Co.
Polymet Mfg. Co.
- COUPLINGS, FLEXIBLE:**
Hammarlund Mfg. Co., Inc.
- CUSHIONS, SPEAKERS:**
Aetna Felt Co.
Western Felt Co.
- DIALS:**
Crowe Nameplate & Mfg. Co.
Hammarlund Mfg. Co.
Scovill Mfg. Co.
United Scientific Laboratories
- DIALS, DRUM:**
Hammarlund Mfg. Co.
United Scientific Laboratories
- DIE-CASTINGS:**
Allied Die-Casting Corp.
- DIES:**
Thomas & Skinner Steel Products Co.
Willor Mfg. Corp.
- DRYER-IMPREGNATORS:**
F. J. Stokes Machine Co.
- DYNAMOTORS:**
Electric Specialty Co.
- ESCUTCHEONS:**
Crowe Nameplate & Mfg. Co.
General Etching & Mfg. Co.
Scovill Mfg. Co.
- EXPORT:**
Ad. Auriema, Inc.
- FADERS:**
Clarostat Mfg. Co.
- FELT, ACOUSTICAL:**
Aetna Felt Co.
American Felt Co.
Booth Felt Co.
Western Felt Co.
- FELT, PACKING:**
Aetna Felt Co.
American Felt Co.
Booth Felt Co.
Western Felt Co.
- FILAMENTS:**
(See Tube Parts)
- FILAMENT CONTROLS, AUTOMATIC:**
Amperite Corp.
Polymet Mfg. Corp.
- FLEXIBLE SHAFTING:**
S. S. White Dental Mfg. Co.
- FOIL:**
Aluminum Co. of America
Johnson Tin Foil & Metal Co.
- GALVANOMETERS:**
General Electric Co.
General Radio Co.
Westinghouse Elec. & Mfg. Co.
- GENERATORS:**
Electric Specialty Co.
- GETTER MATERIAL:**
(See Tube Parts)
- GRAPHITE:**
Acheson Oilclag. Co.
- GRID LEAKS:**
(See Resistances, Fixed)
- HANDLING EQUIPMENT:**
Nat'l. Vulcanized Fibre Co.
- HINGS:**
Scovill Mfg. Co.
- HORNS:**
Amplion Co. of Amer.
- INDUCTANCES, TRANSMITTING:**
General Radio Co.
Jenkins & Adair, Inc.
- INSTRUMENTS, ELECTRICAL:**
General Electric Co.
Westinghouse Elec. & Mfg. Co.

Acoustics!

|||||

Projection Engineering deals editorially with the manufacturing, engineering, operating and servicing of all forms of theatrical equipment, home and theatrical movies, talking movies, television apparatus, etc.

|||||

Keep Pace with Developments
in Talking Movies and
Television

PROJECTION
ENGINEERING
*Is Not Sold on
Newsstands*

SUBSCRIBE NOW!

*Please Check Your
Classification*

Manufacturer
(Including executives, plant superintendents, foremen, purchasing agents, etc.)

Engineer Technician Producer Distributor Theatre Projectionist

BRYAN DAVIS PUBLISHING CO., Inc.
52 Vanderbilt Avenue, New York City

Enclosed find \$2.00 for which enter my subscription for PROJECTION ENGINEERING one year.
for two years.

Name

Address

Town and State

Micro phones

HOME RECORDING » » »

PUBLIC ADDRESS » » » »

STANDARD BROADCAST

**Kellogg Switchboard
and Supply Company**
CHICAGO

Howard B. Jones

TERMINAL STRIPS
for the
ELECTRICAL INDUSTRY



No. 50 Illustrated

Is One of Many Varieties We Carry
in Stock for Assembly to Meet Your
Particular Requirements.

SAMPLES UPON REQUEST

HOWARD B. JONES

2300 WABANSIA AVE.

CHICAGO, ILL.

FELT

For All Radio Uses

AETNA FELT COMPANY
200 Centre Street New York City

OUR SOLE PRODUCTS  FOR OVER 30 YEARS

So good and economical that there is nothing better for MITERED JOINERY
Samples on request

CLAMP NAIL CO., 4540 Palmer St., Cragin Sta. CHICAGO, ILL.

AUTOMATIC STAMPINGS

Send For Samples Of Our HOT TINNING



F. R. Zierick Mfg. Works, 68-72 E. 131st St., New York, N. Y.

CONDENSER PAPER

182 Cornelson Ave. — Mills at — Newark Ave.
Jersey City, N. J. Elizabeth, N. J.

PETER J. SCHWEITZER, Inc.,
200 Fifth Ave. New York

Accurate Mesh—Uniform Selvage For Screen Grids
Accurate mesh and uniform selvage are guaranteed by power-loom weaving. Write telling us your requirements. Samples and prices furnished on request.

BUFFALO WIRE WORKS CO.,
INCORPORATED
(Formerly Scheeler's Sons, Est. 1869)
588 Terrace Buffalo, N. Y.

Baach-International
Compound High Vacuum Pumps

We manufacture all sizes of High Vacuum Pumps from 1-200 cu. ft. per min. All pumps tested at 1/2 micron before leaving factory. Write for details.

INTERNATIONAL MACHINE WORKS, Inc.
527-529 Thirty-Second St., Union City, New Jersey



MICROPHONES

All Kinds from \$7.50 to \$350.00

For Public Address, etc., list..... \$25
Standard Broadcast Model, list..... \$75
Condenser Models for Film and Record Work.
list \$300, \$350.00
Also Desk and Floor Stands, Covers, Cords, etc.
Kits and Parts.

EXPERT MICROPHONE REPAIRS
UNIVERSAL MICROPHONE CO., LTD.
Inglewood, Calif.

Dealers in All Principal Cities
New York—Howard F. Smith—142 Liberty St. Export Dep. Ad.
Aurisma, Inc., 116 Broad St., N. Y. C.

BARE AND TINNED
COPPER WIRE

For All Purposes
Fine Sizes Our Specialty

SPARGO WIRE COMPANY
ROME, NEW YORK
Established 1885

- INSULATION LAMINATED:**
Electrical Insulation Corp.
Formica Insulation Co.
General Electric Co.
National Vulcanized Fibre Co.
Synthane Corp.
- INSULATION, MOULDED:**
Bakelite Corp.
Henry L. Crowley & Co.
Formica Insulation Co.
General Electric Co.
General Plastics Co.
National Vulcanized Fibre Co.
Synthane Corp.
Westinghouse Elec. & Mfg. Co.
- INSULATION, REFRACTORY:**
Henry L. Crowley & Co.
The Stupakoff Labs.
- JACKS:**
General Radio Co.
- KITS, TESTING:**
(See Testing Kits)
- LABORATORIES, TESTING:**
Electrical Testing Labs.
- LACQUER, WOOD:**
Maas & Waldstein Co.
- LACQUER, METAL:**
Maas & Waldstein Co.
- LACQUER, ENAMEL:**
Maas & Waldstein Co.
- LAMINATIONS:**
Thomas & Skinner Steel Products Co.
Willor Mfg. Corp.
- LAMPS, MINIATURE:**
National Carbon Co., Inc.
- LAMPS, PANEL:**
National Carbon Co., Inc.
- LEAD-IN:**
Clarostat Mfg. Co.
Electrad, Inc.
- LOCK WASHERS:**
Shakeproof Lock Washer Co.
Thompson-Bremer & Co.
- LUBRICANTS, RADIO:**
Acheson Oildag Co.
- LUGS:**
Scovill Mfg. Co.
Shakeproof Lock Washer Co.
F. R. Zierick Mfg. Works
- MACHINERY, TUBE:**
Arrow Mfg. & Machine Co., Inc.
Central Scientific Labs.
Eisler Electric Co.
The Engineering Co.
Int'l Machinery Works, Inc.
Lepel High Frequency Labs.
- MACHINES, SPECIAL:**
Willor Mfg. Corp.
- MAGNESIA, TUBES:**
Henry L. Crowley & Co.
The Stupakoff Labs.
- MAGNESIUM:**
Aluminum Co. of America
- MAGNETS:**
Thomas & Skinner Steel Products Co.
- METALS, RARE:**
Fansteel Products Co., Inc.
American Electro Metal Corp.
- METERS:**
General Electric Co.
Weston Elec. Instr. Co.
- MICROPHONES:**
Amplion Co. of America
General Industries Corp.
Jenkins & Adair, Inc.
Kellogg Switchboard & Supply Co.
Universal Microphone Co.
- MOLDING MATERIALS**
(See Insulation, Moulded)
- MOTORS:**
Electric Specialty Co.
- MOTOR-GENERATORS:**
Electric Specialty Co.
- MOUNTINGS, RESISTANCE:**
Polymet Mfg. Corp.
- NAILS:**
Clamp Nail Company
- NAMEPLATES:**
Crowe Nameplate & Mfg. Co.
General Etching & Mfg. Co.
Scovill Mfg. Co.
- NICKEL SILVER:**
Gilby Wire Co.
Phosphor Bronze Smelting Co.
Riverside Metal Co., The
- OHMMETERS:**
General Radio Co.
Weston Elec. Instr. Co.
- OSCILLOGRAPH:**
General Radio Co.
- PACKING PADS, CABINET:**
Aetna Felt Co.
American Felt Co.
Booth Felt Co.
Kimberly-Clark Corp.
Western Felt Co.
- PACKING MATERIAL:**
Holed-Tite Packing, Inc.
Kimberly-Clark Corp.
- PACKING AND SHIPPING:**
Kimberly-Clark Corp.
- PANELS, METAL:**
Aluminum Co. of America
Metal Specialty Co.
Scovill Mfg. Co.
- PAPER, CONDENSER:**
Peter J. Schweitzer, Inc.
- PHONOGRAPH MOTORS:**
The Hammond Clock Co.
- PHOSPHOR BRONZE:**
Baltimore Brass Co.
Phosphor Bronze Smelting Co.
Riverside Metal Co.
- PHOTOELECTRIC CELLS:**
(See Cells)
- PICK-UPS, PHONOGRAPH:**
Amplion Co. of Amer.
Jensen Radio Mfg. Co.
- PLATES, OUTLET:**
Howard B. Jones
- PLUGS, ATTACHMENT:**
General Radio Co.
Howard B. Jones
Polymet Mfg. Corp.
- PORCELAIN TUBING:**
Henry L. Crowley & Co.
The Stupakoff Labs.
- POTENTIOMETERS:**
Clarostat Mfg. Co.
Central Radio Laboratories
General Radio Co.
Polymet Mfg. Corp.
United Scientific Laboratories
- POWER UNITS, A-:**
Thordarson Electric Co.
- POWER UNITS, B-:**
Dongan Elec. Mfg. Co.
General Radio Co.
Thordarson Electric Mfg. Co.
- POWER UNITS, A-B-O:**
American Transformer Co.
Dongan Elec. Mfg. Co.
General Radio Co.
Thordarson Electric Mfg. Co.
- POWER UNITS, PARTS FOR:**
American Transformer Co.
Dongan Elec. Mfg. Co.
General Radio Co.
Kurman Engineering Corp.
Polymet Mfg. Corp.
Thordarson Electric Mfg. Co.
- PRESSED METAL PARTS:**
- PUBLIC ADDRESS SYSTEMS:**
American Transformer Co.
Amplion Corp. of America
Samson Elec. Co.
- PUMPS, HIGH VACUUM:**
Arrow Mfg. & Machine Co., Inc.
Central Scientific Co.
Eisler Elec. Corp.
Int'l Machine Works, Inc.
- PUNCHINGS:**
Aluminum Co. of America
George P. Mitchell & Sons Co.
Scovill Mfg. Co.
Soreng Manufacturing Co.
- PUNCHINGS, BAKELITE:**
Electrical Insulation Corp.
- RECEPTACLES, WALL:**
Scovill Mfg. Co.

- REFRACTORY SPECIALTIES:**
Henry L. Crowley & Co.
The Stupakoff Labs.
- REGULATORS, VOLTAGE:**
Amperite Corp.
Central Radio Laboratories
Claroat Mfg. Co.
DeJur-Amsco Corp.
Polymet Mfg. Corp.
Soreng Manegold Co.
Ward Leonard Elec. Co.
- RELAYS:**
Cardwell, Allen D., Mfg. Co.
- RESISTANCES, FIXED:**
Aerovox Wireless Corp.
Central Radio Laboratories
Claroat Mfg. Co.
The Daven Corp.
DeJur-Amsco Corp.
Frost, Herbert H.
General Electric Co.
Polymet Mfg. Corp.
The S. S. White Dental Mfg. Co.
Ward Leonard Elec. Co.
- RESISTANCES, VARIABLE:**
Central Radio Laboratories
Claroat Mfg. Co.
DeJur-Amsco Corp.
Easton Coil Co.
Frost, Herbert H., Inc.
General Electric Co.
International Resistance Co.
Polymet Mfg. Corp.
Shallcross Mfg. Co.
Ward Leonard Elec. Co.
- RESISTANCE WIRE:**
(See Wire, Resistance)
- RHEOSTATS:**
Central Radio Laboratories
Claroat Mfg. Co.
Frost, Herbert H.
General Radio Co.
Polymet Mfg. Corp.
United Scientific Laboratories
- SCREW MACHINE PRODUCTS:**
Aluminum Co. of America
National Vulcanized Fibre Co.
Scovill Mfg. Co.
Synthane Corp.
- SCREWS, HARDENED SELF-TAPPING:**
Parker-Kalon Corp.
- SCREWS, DRIVE, HARDENED METALLIC:**
Parker-Kalon Corp.
- SEALING COMPOUNDS**
Candy & Co.
Cochrane Chemical Company
- SHEET METAL PARTS:**
George F. Mitchell & Sons Co.
- SHIELDING METAL:**
Aluminum Co. of America
Hammarlund Mfg. Co., Inc.
Radio Products Corp.
- SHORT WAVE APPARATUS:**
Cardwell, Allen D., Co.
De Forrest Radio Corp.
General Radio Co.
Hammarlund Mfg. Co., Inc.
- SOCKETS, TUBE:**
Central Radio Corp.
Henry L. Crowley & Co.
Electrical Insulation Corp.
Frost, Herbert H.
General Radio Co.
Howard B. Jones
Soreng Manegold Co.
- SOLDER:**
Kester Solder Co.
- SPAGHETTI:**
(See Wire, Spaghetti).
- SPEAKERS:**
Amplion Corp. of Amer.
Jensen Radio Mfg. Co.
Potter Co., The
Rola Co., The
Transformer Co. of Amer.
- STAMPINGS, METAL:**
Aluminum Co. of America
George F. Mitchell & Sons Co.
Radio Products Corp.
Scovill Mfg. Co.
Thomas & Skinner Steel Prod. Co.
- PANELS:**
Formica Ins. Co.
General Radio Co.
National Vulcanized Fibre Co.
- SWITCHES:**
Polymet Mfg. Co.
Soreng Manegold Co.
- TAPE, COIL:**
Johnson and Johnson
- TAPE, INDUSTRIAL:**
Johnson and Johnson
- TAPE, LOUD SPEAKER:**
Johnson and Johnson
- TELEVISION PARTS:**
Claroat Co., Inc.
Shallcross Mfg. Co.
- TERMINALS, SOLDER, SCREWS, SPADE:**
Howard B. Jones
Thompson-Bremer & Co.
- TESTERS, B-ELIMINATOR:**
General Radio Co.
- TESTERS, TUBE:**
General Radio Co.
Radio Products Co.
Weston Elec. Inst. Co.
- TESTING INSTRUMENTS:**
General Electric Co.
General Radio Co.
Radio Products Co.
Westinghouse Elec. & Mfg. Co.
Weston Elec. Instrument Corp.
- TESTING KITS:**
General Radio Co.
Weston Elec. Inst. Co.
- TESTING LABORATORIES:**
Electrical Testing Labs.
- TIN COATED METAL:**
Baltimore Brass Co.
- TIN FOIL:**
(See Foil.)
- TOOLS:**
Willor Mfg. Corp.
- TRANSFORMERS, AUDIO:**
Acme Elec. & Mfg. Co.
American Transformer Co.
Dongan Elec. Mfg. Co.
Easton Coil Co.
General Radio Co.
Samson Elec. Co.
Thordarson Electric Mfg. Co.
- TRANSFORMERS, B-POWER UNIT:**
American Transformer Co.
Dongan Elec. Mfg. Co.
General Radio Co.
Kingston Products Corp.
Samson Elec. Co.
Thordarson Electric Mfg. Co.
- TRANSFORMERS, BROADCAST STATION:**
American Transformer Co.
Jenkins & Adair, Inc.
Samson Electric Co.
- TRANSFORMERS, FILAMENT HEATING:**
American Transformer Co.
Dongan Elec. Mfg. Co.
General Radio Co.
Thordarson Electric Mfg. Co.
Transformer Corp. of America
- TRANSFORMERS, OUTPUT:**
American Transformer Co.
Dongan Elec. Mfg. Co.
General Radio Co.
Samson Elec. Co.
Thordarson Electric Mfg. Co.
Transformer Corp. of America
- TRANSFORMERS, POWER:**
Acme Elec. & Mfg. Co.
American Transformer Co.
Dongan Elec. Mfg. Co.
Easton Coil Co.
General Radio Co.
Kingston Products Corp.
Polymet Mfg. Co.
Samson Elec. Co.
Thordarson Electric Mfg. Co.
- TRANSFORMERS, R. F., TUNED:**
Automatic Winding Co.
Cardwell, Allen D. Mfg. Co.
Hammarlund Mfg. Co., Inc.
- TRANSFORMERS, STEP-DOWN:**
American Transformer Co.
Amplion Corp. of Amer.
- TUBE MACHINERY:**
See (Machinery, Tube.)
- TUBE PACKING:**
Holed-Tite Packing, Inc.

OUR
Insulated Wire Strippers
— A Big Help
At Low Cost —
Guaranteed by Trial



We specialize on equipment for removing insulation from any wire or coil lead as required for any electrical connection.

One of our motor driven tools will save you time, money and trouble, and improve quality of work. Let us suggest the best equipment for your job. Descriptive bulletin and low prices mailed on request.

The Wire Stripper Company
566 Erie Bldg., Cleveland, Ohio

GILBY WIRE PRODUCTS

Filament Wire—Gilby Salvage Mesh (pat. app.)
Plain Nickel Mesh—Support Wire—Nickel Ribbon, Plain and Carbonized—Grid Wire—Seamless Tubing—Carbonized Nickel Ribbon.
Standard Nickel Chrome Resistance Wires.
TOPHET "A", TOPHET "C"
Bare & Enameled & Textile Insulated

GILBY WIRE COMPANY
WILBUR B. DRIVER, Pres.
NEWARK NEW JERSEY

STAMPINGS AND METAL BOXES FOR RADIO MANUFACTURERS.

We have served the radio industry from its beginning. We are equipped for quantity production. Submit drawings for quotations.

The G. F. Mitchell & Sons Co.
Plant and Main Office, Cedar & E. 65th St.
Cleveland, O.

WIRE

STRAND—Antennae (plain or enameled)—Double Galvanized.
WIRE—Antennae (plain or enameled). Connecting and Ground (Rubber covered, braided or plain).
RUS BAR—Litzendraht-Loop.
MAGNET (Cotton or Silk)

John A. Roebling's Sons Co., Trenton, N. J.

Indispensable to MODERN RADIO

The new AMPERITE automatically equalizes line-voltage fluctuations. Helps radio sales and satisfaction, because it improves tone, lengthens tube-life and insures uniformly perfect operation. No electric radio is modern without AMPERITE. Does not add to chassis cost.



AMPERITE Corporation
501 BROADWAY, NEW YORK

AMPERITE
Self-Adjusting
LINE VOLTAGE CONTROL

FREE—Technical Bulletin and list of AMPERITE-equipped radios. Address Dept. RE-10.

**NICKEL
WIRE CLOTH**

for the
RADIO TUBE INDUSTRY

Any mesh woven accurately to your specifications.
"CLEVELAND"

Wire Cloth renowned for its Uniformity, its Superiority,
its Durability.

Advise us of your Requirements

The Cleveland Wire Cloth & Manufacturing Co.
3571 E. 78th Street, CLEVELAND, Ohio

FELT

WASHERS, GASKETS, STRIPS, PACKINGS
Write for Catalog and Sample Card

THE BOOTH FELT CO., INC.

481-491 19th Street 737 Sherman Street
Brooklyn, N. Y. Chicago, Ill.

LAMINATIONS
IN ALL TYPES FOR
AUDIO AND POWER TRANSFORMERS—CHOKES

In Stock for Immediate Delivery
Expert Tool and Die Making—
Metal Stampings
Let us quote prices on
quantity you require.

WILLOR MFG. CORP.
117 Mercer St., N. Y. C

WAXES and COMPOUNDS

Impregnating, sealing, filling
Made to individual specifications
Write to

COCHRANE CHEMICAL CO.
430 Danforth Ave. Jersey City, N. J.

Felt

WESTERN FELT WORKS
4029-4133 Ouden Ave., Branches—New York, Boston, Detroit, San
Chicago Francisco, Cleveland, St. Louis, Los Angeles

AUTOMATIC PRECISION MACHINES
For Manufacturing Radio Tubes and Incandescent Lamps

Our new factory with modern facilities enables us to give
prompt service, get our estimate for your requirements, avail
yourself of our Engineering Service.

ARROW MANUFACTURING & MACHINE COMPANY
912 Savoye Street, North Bergen, N. J.

ALPHA WIRE ALPHA

Quality wire for every type of hook-up
"Alpha" a slip back braided hook-up wire made
under a patented process.
Alpha "HiTension" Wire (colored Rubber)
BARE-TINNED-ENAMELED-RUBBER COVERED
—CABLES TO SPECIFICATION—
ALPHA WIRE CORPORATION
522 Broadway, New York City

- TUBE PARTS:**
Acheson Oildag Co.
American Electro Metal Corp.
Buffalo Wire Works Co., Inc.
Callite Products Co., Inc.
Cleveland Wire Cloth & Mfg. Co.
Henry L. Crowley & Co.
The Engineering Co.
Fansteel Products Co., Inc.
General Plastics, Inc.
Gilby Wire Co.
Goat Radio Tube Parts Inc.
Juno Fasteners, Inc.
Lepel High Freq. Labs.
Radio Products Corp.
The Stupakoff Labs.
Synthane Corp., Inc.
(See Parts, Tube.)
- TUBE TESTERS:**
(See Testers, Tube)
- TUBES, A.C.:**
Arcturus Radio Co.
Cable Radio Tube Co.
De Forest Radio Co.
National Carbon Co., Inc.
National Union Radio Corp.
- TUBES, RECTIFIER:**
Arcturus Radio Co.
Cable Radio Tube Co.
De Forest Radio Co.
National Carbon Co., Inc.
National Union Radio Corp.
- TUBES, SCREEN GRID:**
Arcturus Radio Co.
Cable Radio Tube Co.
De Forest Radio Co.
National Carbon Co., Inc.
National Union Radio Corp.
- TUBES, TELEVISION**
See (Cells, Photoelectric.)
- TUBING, NICKEL:**
Gilby Wire Company
- TUBING, PAPER & FIBRE:**
Paper Tube Co.
- TUBING, REFRACTORY:**
Henry L. Crowley & Co., Inc.
Stupakoff Labs, Inc.
- TUBING, VARNISHED:**
Alpha Wire Corp.
- UNITS, SPEAKER:**
Amplion Corp.
Jensen Radio Mfg. Co.
Wright DeCoster, Inc.
- VARNISH:**
Maas & Waldstein Co.
- VOLTAGE REGULATORS:**
(See Regulators)
- VOLTMETERS, A. C.:**
General Electric Co.
General Radio Co.
Weston Elec. Instrument Corp.
- VOLTMETERS, D. C.:**
General Electric Co.
General Radio Co.
Weston Elec. Instrument Corp.
- WASHERS:**
American Felt Co.
Aluminum Co. of America
Booth Felt Co.
Electrical Insulation Corp.
Scovill Mfg. Co.
Synthane Corp.
Thompson-Bremer & Co.
Western Felt Co.
- WAXES, IMPREGNATING:**
Candy and Co.
Cochrane Chemical Company
- WAXES, INSULATING:**
Candy and Co.
Cochrane Chemical Company
- WAXES, SEALING:**
Candy and Co.
Cochrane Chemical Co.
- WIRE, ANTENNA:**
Alpha Wire Corp.
Anaconda Wire & Cable Co.
Cornish Wire Co.
Dudlo Mfg. Corp.
National Vulcanized Fibre Co.
Roebling, J. A., Sons Co.
- WIRE, BARE & TINNED COPPER:**
Alpha Wire Corp.
Anaconda Wire & Cable Co.
Cornish Wire Co.
Dudlo Mfg. Corp.
Roebling, J. A., Sons, Co.
Spargo Wire Co.
- WIRE, COTTON COVERED:**
Anaconda Wire & Cable Co.
Alpha Wire Corp.
Dudlo Mfg. Corp.
Gilby Wire Co.
Polymet Mfg. Corp.
Roebling, J. A., Sons Co.
- WIRE, ENAMELED COPPER**
Alpha Wire Corp.
Anaconda Wire & Cable Co.
Cornish Wire Co.
Dudlo Mfg. Corp.
Polymet Mfg. Corp.
Roebling, J. A., Sons Co.
- WIRE, FILAMENT:**
American Electro Metal Corp.
Callite Products Co., Inc.
Cornish Wire Co.
Fansteel Products Co., Inc.
Gilby Wire Co.
Radio Products Corp.
- WIRE, HOOK-UP:**
Alpha Wire Corp.
Cornish Wire Co.
Dudlo Mfg. Co.
Roebling, J. A., Sons, Co.
- WIRE, LITZENDRAHT:**
Dudlo Mfg. Corp.
Roebling, J. A., Sons Co.
- WIRE, MAGNET:**
Anaconda Wire & Cable Co.
Dudlo Mfg. Corp.
Inon Manufacturing Co.
Polymet Mfg. Corp.
- WIRE, MOLYBDENUM:**
American Electro Metal Corp.
Callite Products Co., Inc.
Fansteel Products Co., Inc.
- WIRE, PIGTAIL:**
Dudlo Mfg. Corp.
Roebling, J. A., Sons Co.
- WIRE, RESISTANCE**
Alloy Metal Wire Co.
Anaconda Wire & Cable Co.
Fansteel Products Co., Inc.
Gilby Wire Co.
- WIRE, SILK COVERED:**
Alpha Wire Corp.
Anaconda Wire & Cable Co.
Cornish Wire Co.
Gilby Wire Co.
Radio Wire Corp.
Roebling, J. A., Sons Co.
- WIRE, SPAGHETTI:**
Alpha Wire Corp.
Cornish Wire Co.
- WIRE STRIPPERS, INSULATED:**
The Wire Stripper Co.
- WIRE, TANTALUM:**
Fansteel Products Co., Inc.
- WIRE, TINNED COPPER:**
Alpha Wire Corp.
Anaconda Wire & Cable Co.
Dudlo Mfg. Corp.
Roebling, J. A., Sons, Co.
- ZINC:**
St. Joseph Lead Co.



"OILDAG"

A long-life radio parts lubricant containing ten per cent colloidal electric-furnace graphite.

Write for Technical Bulletin on "The Use of 'Oildag' as a Radio Parts Lubricant."

ACHESON OILDAG COMPANY
PORT HURON, MICH.

Made by the makers of "Aquadag."

COMPLETE LINE

Immediate Delivery *Write for Bulletin 931*

GENERAL RADIO CO. PARTS

LEEDS

The Home of RADIO

45 VESEY STREET, NEW YORK CITY

BRASS—BRONZE—COPPER

NICKEL SILVER—ZINC

PHOSPHOR BRONZE

In Gauges .001 and Thicker. 1/16" to 16" Wide

TIN COATED METALS IN COILS AND STRIPS

THE BALTIMORE BRASS CO.
1206 WICOMICO ST., BALTIMORE, MD.

LAMINATIONS

for Audio & Power Transformers

SPECIALIZED METHODS—YEARS OF EXPERIENCE

Wide Variety of Stock Standard Sizes

Dimension and Price Sheets on request

We Also Make

PERMANENT MAGNETS—DIES—TOOLS—METAL STAMPINGS

Facilities for prompt service

=

Thomas & Skinner
Steel Products Co.

1100 to 1120 E. Twenty-Third St. INDIANAPOLIS, IND.



Type 404 Test-Signal Generator. Price \$95.00

Sensitivity Measurements For The Service Man

THIS new General Radio instrument makes it possible for the independent service man to make sensitivity measurements on radio receivers in addition to the usual neutralizing and aligning adjustment tests. When used in conjunction with an output power-measuring device the Type 404 Test-Signal Generator will show the approximate sensitivity of a receiver at any point in the broadcast band.

Further details will be supplied on request to all who ask for them on their business letterhead.

GENERAL RADIO COMPANY

Offices Laboratories Factory
CAMBRIDGE A, MASSACHUSETTS

Pacific Coast Warehouse: 274 Brannan St., San Francisco

FAIRMONT ALUMINUM



Pure and Alloy

SHEET

for

Radio Production

Fairmont Aluminum Company
Fairmont, W. VA.

Formerly Fairmont Manufacturing Company.

Branch Sales Offices at

52 Vanderbilt Ave. Monadnock Block General Motors Bldg.
New York Chicago Detroit

Warehouse Distributors

Central Steel and Wire Company, Chicago; Chas. A. Strelinger Co., Detroit; J. M. & L. A. Osborn Co., Cleveland; Ducommun Corporation, Los Angeles and San Francisco.

REPLACEMENT FILTER CONDENSERS		CARBON RESISTORS—PIG TAILS			
Compact—especially designed for service men and for general replacement in condenser blocks.		130 ohm	1,500 ohm	20,000 ohm	75,000 ohm
1 mfd. — 600 DC working voltage45 ea.	500 "	10,000 "	25,000 "	100,000 "
2 " — 600 " " " "65 "	1,000 "	15,000 "	50,000 "	250,000 "
1 " — 450 " " " "30 "	Packed in dozen lots @ \$1.10 per dozen.			
2 " — 450 " " " "40 "	Send for our latest list of power transformers and other replacement parts—all at "SPECIAL PRICES."			
4 " — 450 " " " "60 "	All condensers are guaranteed accurate.			
F. O. B. New York		W. K. SKIDMORE & COMPANY		17 Warren Street, New York	

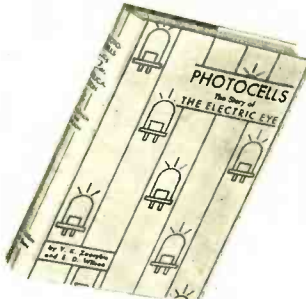

a modern book on a modern subject

Photocells and their Application

By
V. K. Zworykin and
E. D. Wilson

Research Engineers, Westinghouse Research Laboratories

Presents a comprehensive discussion of the theory of radiation and the photoemissive effect, the methods of preparing photocells, the various types of cells. The latter half of the book is devoted to a modern treatment of the manifold applications of photocells—their use in sound movies, in facsimile transmission, in television, and many others of the greatest importance. The book is concluded with a glimpse into the future of photocells, indicating the trend of advancement and improvement.

209 pages
5½ by 8½
\$2.50

ON APPROVAL COUPON
JOHN WILEY and SONS, INC.,
440 Fourth Ave., New York

Gentlemen: Kindly send me for free examination Zworykin's "Photocells." I agree to remit the price of the book (\$2.50) within ten days after its receipt or return it post-paid.

Name

Address

Position or Reference.....

RE 10-30

HERE IS THE BARGAIN CATALOGUE YOU'VE WAITED FOR!



Wholesale Radio & Electrical
Bargain Bulletin No. 65

DEALERS, SERVICE - MEN,
JOBBER, MANUFACTURERS
!! NOW READY !!

New Wholesale Bargain Bulletin No. 65. Full of Real Low Prices on: Condensers, Transformers, Speakers, and Replacement Parts.

Hundreds of items at Remarkably Low Prices
Just write for it Today

AMERICAN SALES CO.
19-21 WARREN ST. Dept. R NEW YORK CITY



DEALERS AND SERVICEMEN

Write for Your FREE Copy of this BIG Catalog

40 PAGES
OVER 1,000 ITEMS OF REPLACEMENT PARTS FOR ALL STANDARD SETS

Write Now

Federated Purchaser
220 HUDSON STREET
NEW YORK, N.Y.

SEND FOR LATEST ISSUE OF

NUBOR FLASHES

Hundreds of bargains in Radio and Electrical Merchandise
NUBOR RADIO CO., 12 R Warren St., New York City

See Page 53

TESTING OF RADIO APPARATUS

LIFE TESTS AND CHARACTERISTICS OF VACUUM TUBES
CALIBRATION OF ALL KINDS OF INSTRUMENTS

Determination of Inductance and Capacitance at Various Frequencies
Resistance Measurements, Magnetic Tests, Motor Tests, etc.

80th St., and East End Ave. ELECTRICAL TESTING LABORATORIES New York City, N. Y.

WE offer to manufacturers interested in EXPORT

the services of a dependable organization, well established in the entire foreign field

AD. AURIEMA, INC.

Manufacturers' Export Managers

116 Broad Street, New York, N. Y.

D'Arcy Laboratories

place at your disposal their laboratory facilities for your assistance in volume control problems.

Bulletin M.I. is now ready for those who inquire for it.

D'Arcy Laboratories

160 A. East Illinois Street Chicago, Illinois

STATEMENT OF THE OWNERSHIP, MANAGEMENT, CIRCULATION, ETC., REQUIRED BY THE ACT OF CONGRESS OF AUGUST 24, 1912, OF RADIO ENGINEERING.

Published monthly at Albany, N. Y., for October 1, 1930.

State of New York } ss.
County of New York }

Before me, a Notary Public in and for the State and county aforesaid, personally appeared B. S. Davis, who, having been duly sworn according to law, deposes and says that he is the Business Manager of RADIO ENGINEERING, and that the following is, to the best of his knowledge and belief, a true statement of the ownership, management, etc., of the aforesaid publication for the date shown in the above caption, required by the Act of August 24th, 1912, embodied in section 411, Postal Laws and Regulations, to wit: 1. That the names and addresses of the publisher, editor, managing editor, and business managers are: Publisher, Bryan Davis Publishing Co., Inc., 52 Vanderbilt Avenue, New York; Editor, Donald McNichol, Roselle Park, N. J.; managing editor, F. Walen, Union City, N. J.; Business Manager, B. S. Davis, Scarsdale, N. Y. 2. That the owners are: B. S. Davis, Scarsdale, N. Y.; Roy T. Atwood, Albany, N. Y. 3. That the known bondholders, mortgagees, and other security holders owning or holding 1% or more of the total amount of bonds, mortgages, or other securities are: None. 4. That the two paragraphs next above, giving the names of the owners, stockholders, and security holders, if any, contain not only the list of stockholders and security holders as they appear upon the books of the company but also, in cases where a stockholder or security holder appears upon the books of the company as trustee or in any other fiduciary relation, the name of the person or corporation for whom such trustee is acting, is given; also that the said two paragraphs contain statements embracing affiant's full knowledge and belief as to the circumstances and conditions under which stockholders and security holders who do not appear upon the books of the company as trustees, hold stock and securities in capacity other than that of a bona fide owner; and this affiant has no reason to believe that any other person, association, or corporation has any interest direct or indirect in the said stock, bonds, or other securities than as so stated by him.

(Signed) B. S. DAVIS, Business Manager.

Sworn to and subscribed before me this 1st day of October, 1930.
(Seal) J. A. WALKER, Notary Public.

Kings County,
Kings Co., Clerk's No. 363.
Kings Co., Registers No. 1062.
New York Co., Clerk's No. 167.
New York Co., Registers No. 1W177.
Commission expires March 30, 1931.

BYRD'S Antarctic Radio Equipment

The advanced types of receivers, transmitters, and navigation aids that triumphed on this epochal flight now fully described in this book.

TELEVISION

Mr. C. F. Jenkins, father of television and radio movies, gives you in his own words complete directions for building practical television equipment.

INTER-FERENCE ELIMINATION

Tracking down troublesome interference and eliminating it systematically outlined by W. F. Fleming, radio engineer.

RADIO AUTO-ALARM

New automatic device on ships to keep the SOS watch while operator is off duty—fully described in this book.

Latest BROADCASTING EQUIPMENT

Temperature - controlled Piezo crystal oscillator, 100% modulation panel, and other new apparatus, completely described, with instructions for operation.

SHORT-WAVE Apparatus

Latest types of commercial and amateur short-wave apparatus; directions for securing operator's and station license.

Marine and Aerial Radio Equipment

Radio beacons; arc radio transmitter for ships; Reed course indicator; latest developments in high frequency transmitters.

New RADIO LAWS and REGULATIONS

New regulations governing all classes of operators' licenses, U. S. Laws, and I. R. T. C. Laws.

New Developments!

Complete Instructions and Data on All Recent Radio Inventions Now Yours For Ready Reference in This One Big Guide Book of Radio



THE RADIO MANUAL

A Handbook for Students, Amateurs, Operators and Inspectors

Here's the answer to every question about the principles, operation, and maintenance of apparatus for radio transmitting and receiving. No detail has been omitted, from elementary electricity and magnetism for the beginner to television and radio movies. Important new chapters have been added to bring it right up-to-the-minute, and an immense volume of facts never before available is now presented in the book. Included are detailed descriptions of standard equipment, fully illustrated with photographs and diagrams. It is now more than ever the one complete handbook covering the entire radio field.

A Complete Course in Radio Operation

IN ONE VOLUME
Enables You to Qualify for Gov't. License As Operator or Inspector
20 Big Chapters Cover:

Elementary Electricity and Magnetism; Motors and Generators; Storage Batteries and Charging Circuits; The Vacuum Tube; Circuits Employed in Vacuum Tube Transmitters; Modulating Systems and 100% Modulation; Wave-Meters; Piezo-Electric Oscillators; Wave Traps; Marine Vacuum Tube Transmitters; Radio Broadcasting Equipment; Arc Transmitters; Spark Transmitters; Commercial Radio Receivers; Marconi Auto-Alarm; Radio Beacons and Direction Finders; Aircraft Radio Equipment; Practical Television and Radio Movies; Eliminating Radio Interference; Radio Laws and Regulations; Handling and Abstracting Traffic.

Prepared By Official Examining Officer

The author, G. E. STERLING, is Radio Inspector and Examining Officer, Radio Division, U. S. Dept. of Commerce. The book has been edited in detail by ROBERT S. KRUSE, for five years Technical Editor of Q S T, the Magazine of the American Radio Relay League, now Radio Consultant. Many other experts assisted them.

Examine It FREE!

The latest edition of "The Radio Manual" has just been published. Nearly 800 pages, 369 illustrations. Bound in Flexible Fabricoid. The coupon brings the volume for free examination. If you do not agree that it is the best Radio book you have seen, return it and owe nothing. If you keep it, send the price of \$6.00 within ten days.

MAIL THIS COUPON TODAY

D. VAN NOSTRAND CO., Inc.,
250 Fourth Ave., New York.
Send me the Revised edition of THE RADIO MANUAL for examination. Within ten days after receipt I will either return the volume or send you \$6.00, the price in full. (R.E. 10-30)

Name

St. and No.

City and State

Business Connection

Tube Parts

▼

PLATES

(all types)

GETTER CUPS
FILAMENT HOOKS
CATHODES

▼

Special parts to order.

Send us your specifications.

JUNO FASTENERS, Inc.
26-32 Sterling St. E. Orange, N. J.

DEPENDABLE

QUALITY — UNIFORMITY
SERVICE
ON
WAXES — & — MELTABLE
INSULATING and WEATHER-
PROOFING COMPOUNDS

WAXES—All kinds.

IMPREGNATIONS—Condensers, Coils, Rubber-Covered and Weather-Proofed Wire, Telephone and Electrical Cables, Etc.

SEALING COMPOUNDS—Coils, Condensers, Batteries (Wet & Dry), Pot Heads, Cables, Wiring Devices and Specials.

FINISHING—All grades of Weather Proof and Rubber-Covered Wire.

SPECIAL COMPOUNDS



35th St. & Maplewood Ave.
Chicago, Ill.
"For over 35 yrs."

INDEX OF ADVERTISERS

<p>A</p> <p>Acheson-Oildag Co. 61 Ad. Aurlima, Inc. 63 Aetna Felt Co. 58 Allied Die Casting Corp. 51 Alpha Wire Corp. 60 Aluminum Company of America. 15 American Sales Co. 63 Amerlite Corp. 59 Anaconda Wire & Cable Co. 5 Areturus Radio Tube Co. 45 Arrow Mfg. & Mach. Co., Inc. 60</p> <p>B</p> <p>Bakelite Corp. Back Cover Baltimore Brass Co., The. 61 Baltimore Radio Co. 62 Booth Felt Co., The. 60 Buffalo Wire Works Co., Inc. 58 Buyers Directory. 56, 58, 59, 60</p> <p>C</p> <p>Candy & Co. 64 Central Radio Corp. 6-7 Central Radio Laboratories. 43 Central Scientific Co. Second Cover Clamp Nail Co. 62 Claroostat Mfg. Co., Inc. 14 Cleveland Wire Cloth & Mfg. Co., The. 60 Cochrane Chemical Co. 60 Condenser Corp. of America. 54 Crowley, Henry & Co. 65</p> <p>D</p> <p>Daven Co., The. 65 D'Arcy Laboratories. 63 DeForest Radio Co. 17 De Jur-Amsco Corp. 52 Dongan Elec. Mfg. Co. Third Cover</p> <p>E</p> <p>Eisler Electric Corp. 65 Electrical Testing Labs. 62</p>	<p>F</p> <p>Fairmont Aluminum Co. 61 Fansteel Products Co., Inc. 13 Federated Purchaser. 62 Formica Insulation Co. 1 Frost, Herbert H., Inc. 47</p> <p>G</p> <p>General Cable Corp. 19-21 General Electric Co. 22 General Etching & Mfg. Co. 54 General Radio Co. 61 Gilby Wire Co. 59</p> <p>I</p> <p>Inca Division. 11 Igrad Condenser Mfg. Co. 54 Int'l Machine Works, Inc. 58</p> <p>J</p> <p>Jenkins & Adair, Inc. 54 Johnston Tin Foil & Metal Co. 54 Johnson & Johnson. 65 Jones, Howard B. 57 Juno Fasteners, Inc. 64</p> <p>K</p> <p>Kellogg Switchboard & Supply Co. 57 Kester Solder Co. 55 Kingston Products Corp. 54</p> <p>L</p> <p>Leeds Radio Co. 61</p> <p>M</p> <p>Mitchell & Sons Co., The G. F. 59</p> <p>N</p> <p>National Carbon Co., Inc. 49 National Elec. Products Corp. 11 National Union Radio Corp. 8</p>	<p>N</p> <p>National Vul. Fibre Co. 66 Nabor Radio Co. 62</p> <p>P</p> <p>Parker-Kalon Corp. 3 Polymet Mfg. Co. 12</p> <p>R</p> <p>Radio Products Co., The. 53 Radio Products Corp. 51 Roebbling, J. A., Sons Co. 59</p> <p>S</p> <p>Sangamo Electric Co. 9-10 Schweitzer, Peter J., Inc. 58 Scovill Mfg. Co. 18 Shallcross Mfg. Co. 52 Skidmore & Co., W. K. 62 Soreng Manegold Co. 54 Spargo Wire Co. 58 Synthane Corp., Inc. 54</p> <p>T</p> <p>Thomas & Skinner Steel Products Co. 61 Thompson-Bremer & Co. 47 Thordarson Electric Mfg. Co. 49</p> <p>U</p> <p>Universal Microphone Co., Ltd. 58</p> <p>V</p> <p>Van Nostrand Co., D. 63</p> <p>W</p> <p>Ward Leonard Elec. Co. 66 Western Felt Works. 60 Weston Elec. Inst. Corp. 45 Wiley, John, & Sons, Corp. 62 Willor Mfg. Corp. 60 Wire Stripper Co., The. 59</p> <p>Z</p> <p>Zapon Co., The. 52 Zierick Mfg. Works, F. R. 58</p>
---	---	--

RADIO TUBE MACHINERY
INCANDESCENT LAMP MACHINERY
TELEVISION TUBE MACHINERY
NEON SIGN MACHINERY
GLASS WORKING MACHINERY
HIGH VACUUM PUMPS
ELECTRIC SPOT WELDERS
LABORATORY GLASS BURNER APPARATUS

EISLER
ELECTRIC
MACHINERY

Send For New "C" Catalog
EISLER ELECTRIC CORPORATION
 760 So. 13th St. Newark, N. J.

SUPER-DAVOHM

Wire Wound Precision Resistors

Type BLT

Type BWE

Super-Davohms are known and used in the entire world. Instrument manufacturers have adopted the Super-Davohm as an integral part of their assembled unit. Universities, electrical, physical, instrument and radio research laboratories are using Super-Davohms as laboratory standards because of their excellent characteristics.

Recommended for: Television Amplifiers, Telephone Equipment, Sound Picture Equipment, Fire Alarm Equipment, Voltmeter Multipliers, Resistance Amplifiers, Electrical Instruments, Laboratory Standard Resistors, Attenuators and Fading Controls.

(ACTUAL SIZE)

Send Us Your Resistor Specifications
Samples on Request
THE DAVEN COMPANY
 RESISTOR SPECIALISTS
 General Office and Factory
 158-160 Summit Street, Newark, New Jersey

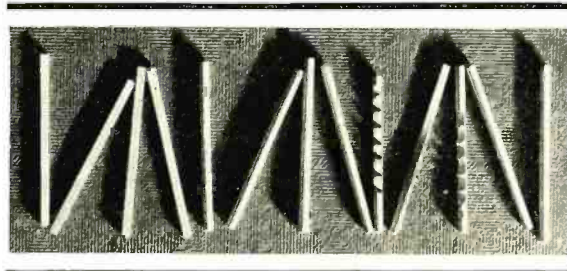

Speeding the Heating

Quicker heating A.C. tubes—that's what radio public and trade have long demanded. But—and here's the big point—the price of quick heating was noise, uncertainty, short life. Could we develop insulator tubing that would heat in a few seconds and still retain the electrical, mechanical, chemical and thermal requisites? We went to work on the problem, finally evolving



A special magnesia formula for quick-heating tubes. Greatly reduced heating time at no sacrifice of quiet operation and long life. Electrical, mechanical and thermal qualities that permit cutting bulk to a minimum. Readily machined. These and other advantages are manifested in the ideal quick-heating A.C. tubes of today, with their round, flat or notched CROLITE tubing, insulating heater wires in cathode sleeve.

Write us, whatever your problems may be. Perhaps we have already developed—if not, we can develop—a severe service material to meet your most trying conditions.

HENRY L. CROWLEY & COMPANY, Inc.
Specialists in Severe Service Materials
 1 Central Avenue West Orange, N. J.

RADIO MAKERS

throughout the country now know
THERE'S NO SUBSTITUTE FOR

JOHNSON'S

INDUSTRIAL TAPE

TAPE has become not only the most practical but also a very important cost item in its various applications for the construction of the chassis and cabinet of radios. Johnson's first of all insures your using a quality product. Its exceptional properties of adhesion permit the use of extremely narrow width without loss of holding power. This is only one of the big savings and reasons for its preference by leading radio manufacturers.

Have you seen the new Johnson's Tape Dispenser?
Holds full size roll of tape up to 1 1/4 inches wide.
Enables you to cut any length of tape instantly.
Eliminates pre-handling—no waste.

MAKE THE TEST WITHOUT COST

JOHNSON & JOHNSON, New Brunswick, N. J. R. E. O.
 Please send free sample roll of Johnson's Industrial Tape and information on the Tape Dispenser.

Name _____
 Company _____
 Street and No. _____
 City _____ State _____

VITROHM **WL** RESISTORS

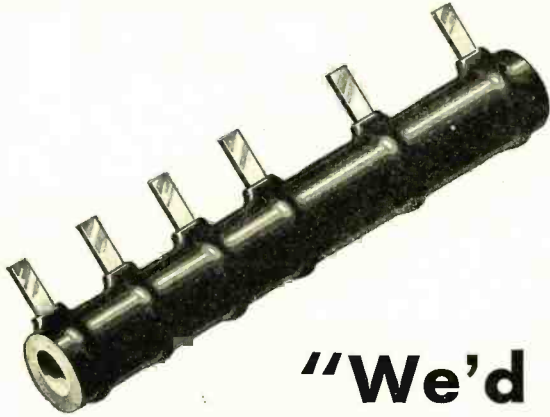

"We'd Like to Get—"

OUR Sales Department doesn't answer people who want an especially difficult resistor job with, "so do we." It isn't polite and, frequently, today's NO is tomorrow's YES, for our Engineering and Research Departments are always busy at the job of making possible the impossible with all types of resistor designs.

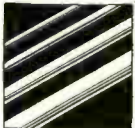

There are many sizes and kinds of resistance wire



Each lot of wire is carefully tested for tensile strength



An ingenious machine rejects all kinked or distorted wire

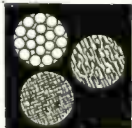

One wire cannot be used for all applications. The duty dictates the choice



Neglect of any detail means trouble later



Wire specifications drawn by Ward Leonard are rigid. It protects you.

During the past few months VITROHM **WL** RESISTORS have become available in many new types and sizes. If you have a resistor problem, tell us; the chances are excellent that we have what you want.

WARD LEONARD ELECTRIC CO.
Mount Vernon, New York
resistor specialists for more than 39 years

Thinking in the right material

In commerce too, not only in industries—in every business in which goods or materials are handled—men and managers are looking for every way that can better the work, the handling, or safeguarding of values. They know that the rightness of their equipment depends, fundamentally, on the rightness of the material of which it is made.

What they can learn from modern trucks, boxes, conveyors

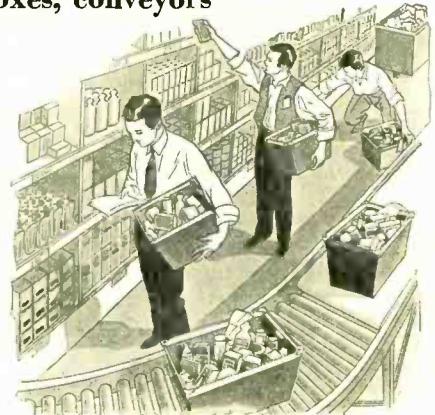

LIFTED, pushed, transported repeatedly; so every hundredth of an ounce counts. Thrown, dropped, stacked, squeezed . . . Boxes and trays loaded with contents many times their own weight. The strength must be there—and utmost durability—and utmost lightness—and safety of materials and product against damage.

Other factors too—the workers' time, attention, motions, convenience, accuracy . . . smoothness and sureness of traffic flow . . . management factors, etc. For such equipment nothing equals NVF.

We make both Vulcanized Fibre and Phenolites (reinforced laminated Bakelite materials). Ten standard kinds of Vulcanized Fibre, including Peerless Insulation and Leatheroid. For electrical insulating and mechanical uses. Direct representatives in principal cities of the United States, Canada and Europe.

NATIONAL VULCANIZED FIBRE CO.
WILMINGTON, DELAWARE

NVF

The beginning of every advancement, in equipment or product, must always be:

thinking in the right material

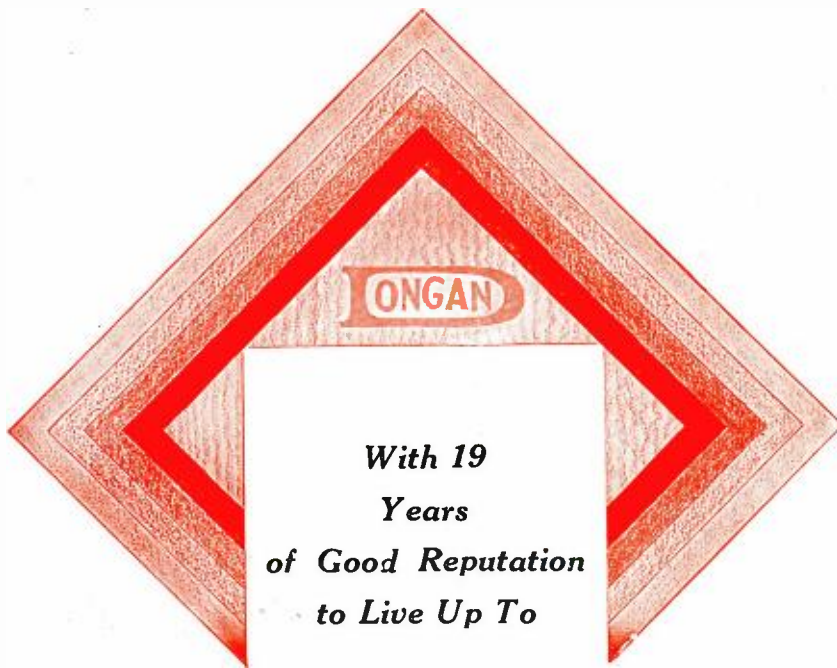

WE MAKE THIS PLEDGE

In the past year many buyers have congratulated themselves upon the voluntary price reductions offered to them by eager suppliers. Yet, lower prices sometimes signify a desperate desire rather than sound economies.

During that period Dongan has not in any instance purchased cheaper raw materials. On the contrary new equipment has been added and the quality of the product has actually been improved.

To the Radio Set Manufacturer Dongan offers a pledge. First and last, subordinating all other considerations, Dongan Transformers will be built to the finest standard of design and quality. If, after quality is assured, any manufacturing improvements or economies can be effected with a consequent reduction in the cost, the advantage in price will be passed along most willingly to our customers.

It is upon such policies that we have weathered all storms for 19 years and so today can, from a most solid foundation, assure you of the best in Radio Transformers.

Dongan Electric Manufacturing Co.
2991-3001 Franklin St., Detroit



B-22

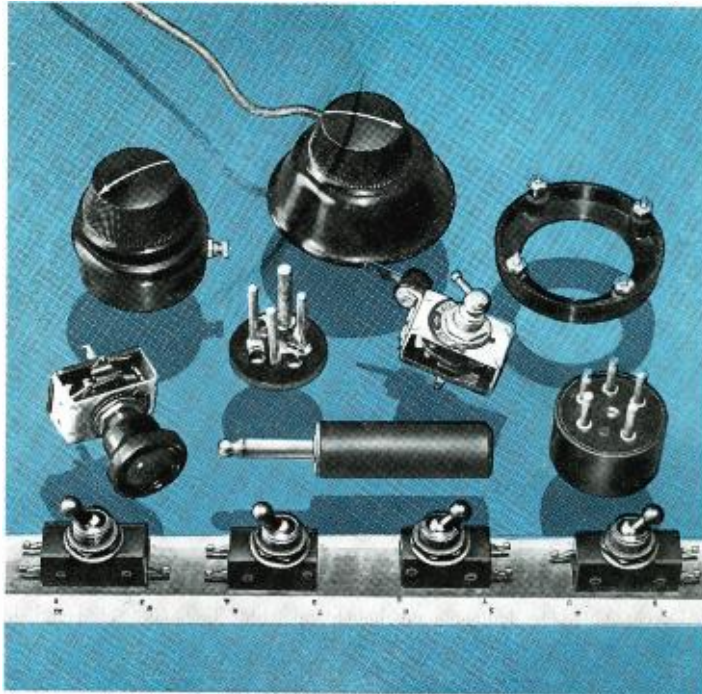

Switches and Radio Parts made with Bakelite Materials. Carter Radio Co., Chicago.

"ITS FINISHED APPEARANCE ELIMINATES SALES RESISTANCE"

This midget A.C. Toggle Switch, is as accurately formed and finely finished as any of its big brothers. The compact Bakelite Molded housing made the production of the little switch practical, and the use of a 24 cavity mold made it economical. Carter says that "the finished appearance of the Bakelite Molded switch eliminates sales resistance."

For making a great variety of radio accessories and parts, Carter has found the use of Bakelite Materials to be a real production economy, and a distinct sales

advantage. Just a few of these are shown with the switches in the photograph above.

You will find a Bakelite Insulation Material exactly suited to any radio requirement. Bakelite Molded in several colors and types—Bakelite Laminated in sheets, tubes and rods, and Bakelite Varnish for coil impregnation. All are non-hygroscopic, moisture and age resistant, and of high insulation value. Write to us for copies of Booklets 38M, 38L, and 38V, describing various Bakelite Materials.

Bakelite Engineering Service—We manufacture a wide variety of Bakelite resinoid molding materials, varnishes, lacquers, enamels, cements, and other products. Twenty years experience in the development of these materials for radio and other uses, provides a valuable background for the cooperation offered by our engineers and laboratories.

BAKELITE CORPORATION, 247 Park Avenue, New York. **CHICAGO OFFICE**, 635 West Twenty-second Street
BAKELITE CORPORATION OF CANADA, LIMITED, 163 Dufferin Street, Toronto, Ontario

BAKELITE

REGISTERED U. S. PAT. OFF.



*The registered Trade Mark and Symbol shown may be used only on products made from materials manufactured by Bakelite Corporation. Under the copyright "B" is the numerical sign for infinity, or unlimited quantity. It symbolizes the infinite number of present and future uses of Bakelite Corporation's products.

THE MATERIAL OF A THOUSAND USES